

English

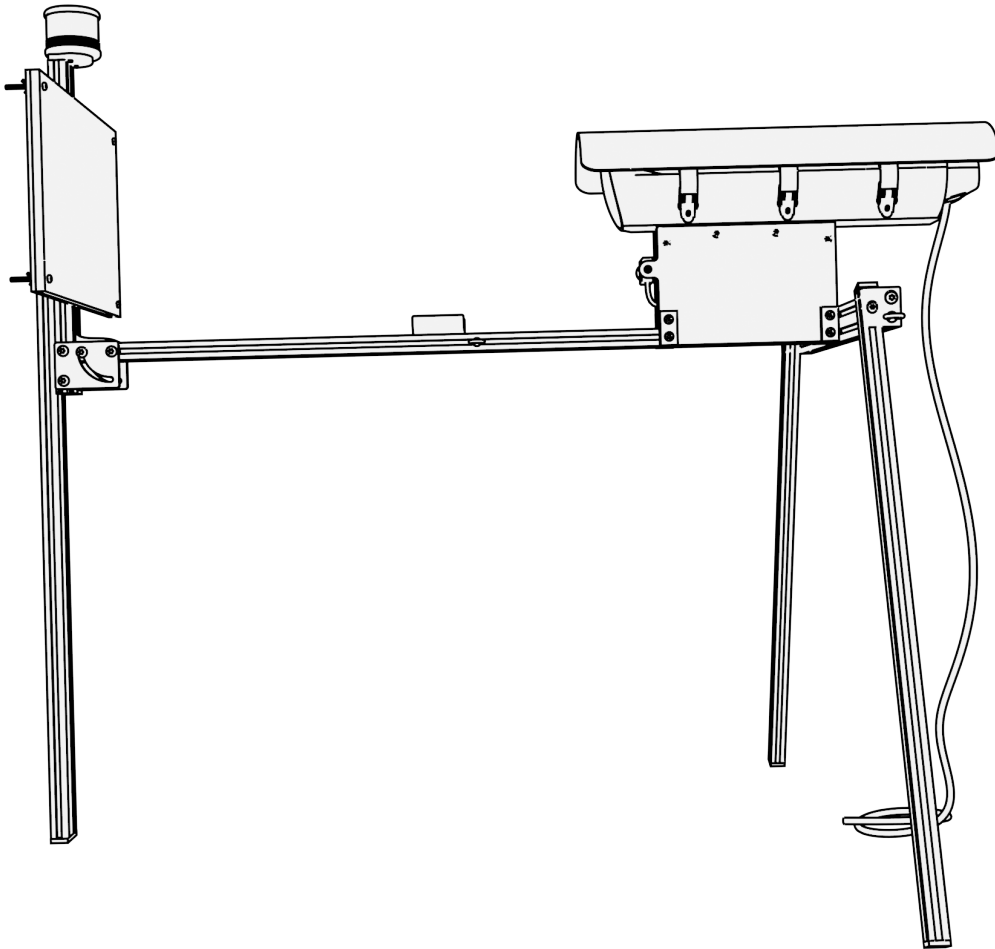

Automated recorder of nocturnal Insectes - Pro model (ARNI-Pro) Set up guide



BMBF Research Initiative for the
Conservation of Biodiversity



Bundesministerium
für Forschung, Technologie
und Raumfahrt



openUC2

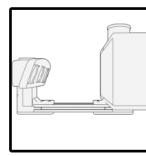
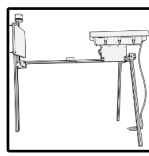

Table of Content

1 Safety instructions	4	
2 Generations	5	
3 Components	6	
3.1 Rack	6	
3.2 Camera housing	7	
3.3 Details	8	
4 Setting up the ARNI	10	
4.1 Tools	10	
4.2 Overview	10	
4.3 Assembly	11	
5 Power connection	19	
5.1 Option A – Power grid.....	19	
5.2 Option B – Solar panel and charge controller	20	
5.3 Protection against deep discharge	21	
6 Opening/closing the camera housing	22	
7 Switch on	23	
8 Start sequence	24	
8.1 Control software for the Raspberry Pi	24	
8.2 Control software for 'LEPMON_solar'	25	
9 Input menu	26	
10 Hidden menu	27	
10.1 Change language	27	
10.2 Focus.....	28	
11 Visible menu	32	
11.1 Power supply, storage deletion, heating	32	
11.2 Setting the date and time.....	34	
11.3 Enter GPS coordinates	36	
11.4 Enter LEPMON code	39	
12 Diagnostics	41	
12.1 Sensors	41	
12.2 Camera.....	43	
12.3 USB and twilight times	45	
13 Maintenance	47	
13.1 During the season	47	
13.2 After the season	47	
13.3 Replacing the RTC battery	48	

Safety

Compo-
nents

Setup

Power

Start

Menu
hidden

Menu

Diagnostics

Service

Errors

Output

LEPMON
Code

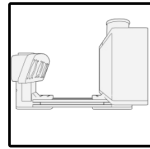
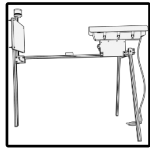
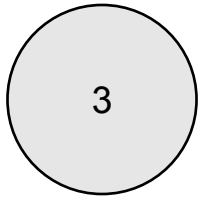

14 Firmware-Update	49
15 errors	53
16 Output.....	59
16.1 Sample log file	59
16.2 Metadata table.....	66
16.3 images	67
17 Available LEPMON-Codes	68
18 Promotion.....	80

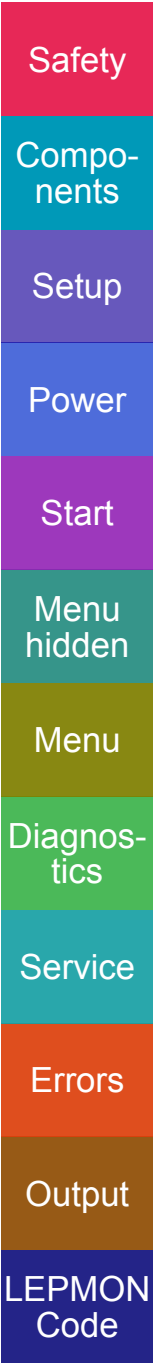

This manual describes firmware version 2.3.2 released 21.05.2026.

- If your ARNI is running an older version, you can find the appropriate instructions for download at <https://lepmon.de/en/arni-manual/>.
- This manual focuses on Pro 3 and 4 generation ARNIs (Pro_Gen_3 and Pro_Gen_4). In many respects, such as the firmware, there are similarities with the citizen science version (CS_Gen_1). Icons in the header indicate this.

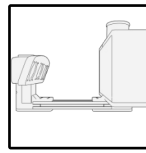
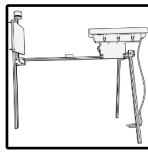

1 Safety instructions

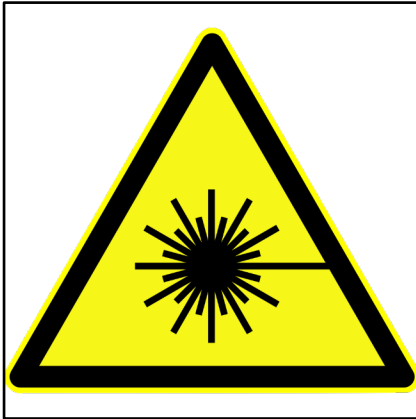

UV

The Automated Recorder for Nocturnal Insects (ARNI) uses a UV lamp. When operating the lamp, always **maintain a distance of at least 50 cm**. Do not look directly into the UV lamp. No precautions are necessary as long as the device is not connected to the power supply.

Safety



Rain

ARNI is fundamentally protected against splashing water. Once components are opened, e.g. during installation or maintenance, this protection is no longer guaranteed. If moisture enters the housing, the windscreen [heater](#) can be activated in the menu.

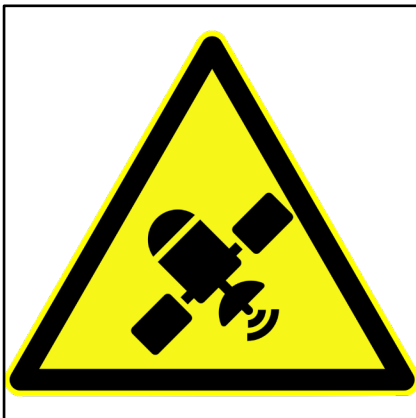

GPS

ARNI has a hidden GPS module and transmits its location.



camera surveillance

ARNI takes pictures of the white foam surface. The spotlight under the camera housing lights up with each picture.

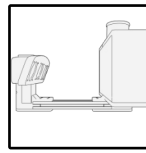
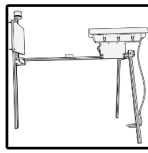

2 Generations

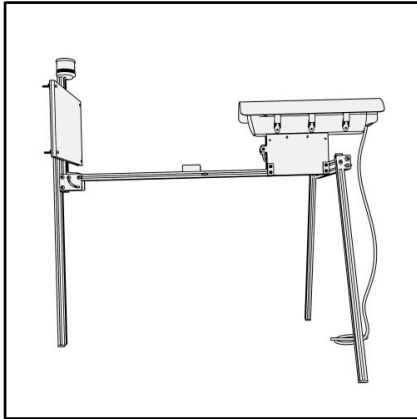

Pro_Gen_1 and Pro_Gen_2

Prototype series of the ARNI, operated exclusively by the LEPMON project and in Jena.

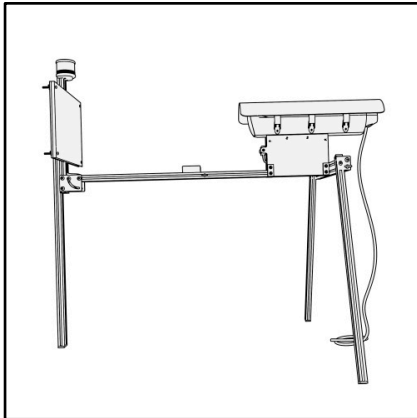

Pro_Gen_3 and Pro_Gen_4

Series variants of the ARNI-Pro model. ARNI says the device generation in the [start sequence](#). Both generations are almost identical in design and differ mainly in their [control electronics](#). The most important difference is that Pro_Gen_4 has integrated [protection against deep discharge](#) to protect the [battery](#).

Pro_Gen_3 was awarded by the LEPMON project. From 2026 onwards, only Pro_Gen_4 will be distributed by K2W.

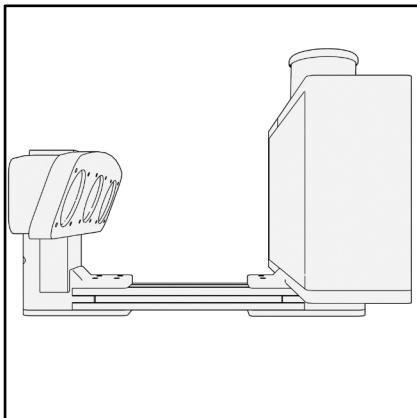

CS_Gen_1

The citizen science variants of ARNI (ARNI-CS) are expected to be available in the spring of 2026.

Compo-
nents

6

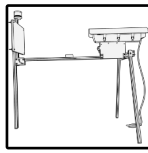

3 Components

3.1 Rack

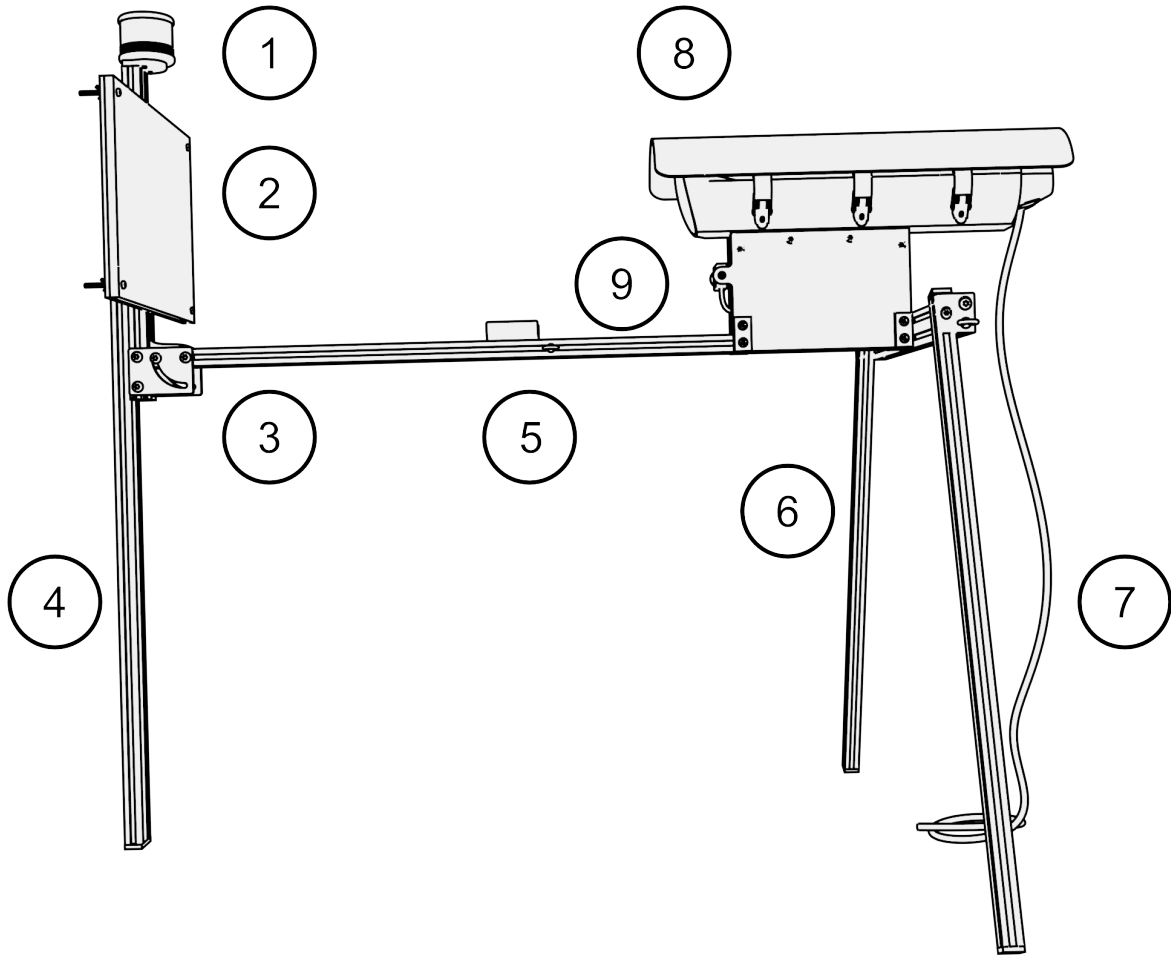

Compo-
nents

- | | | | |
|---|-----------------------------------|---|--|
| 1 | UV-Lamp | 6 | Rear pair of legs with cross strut |
| 2 | Canvas | 7 | Power cable |
| 3 | Hinge | 8 | Camera housing |
| 4 | Front leg | 9 | Spotlight (on the Pro Gen 4 in the camera housing) |
| 5 | Longitudinal bar with lamp holder | | |

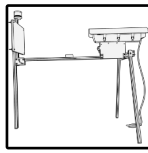

3.2 Camera housing

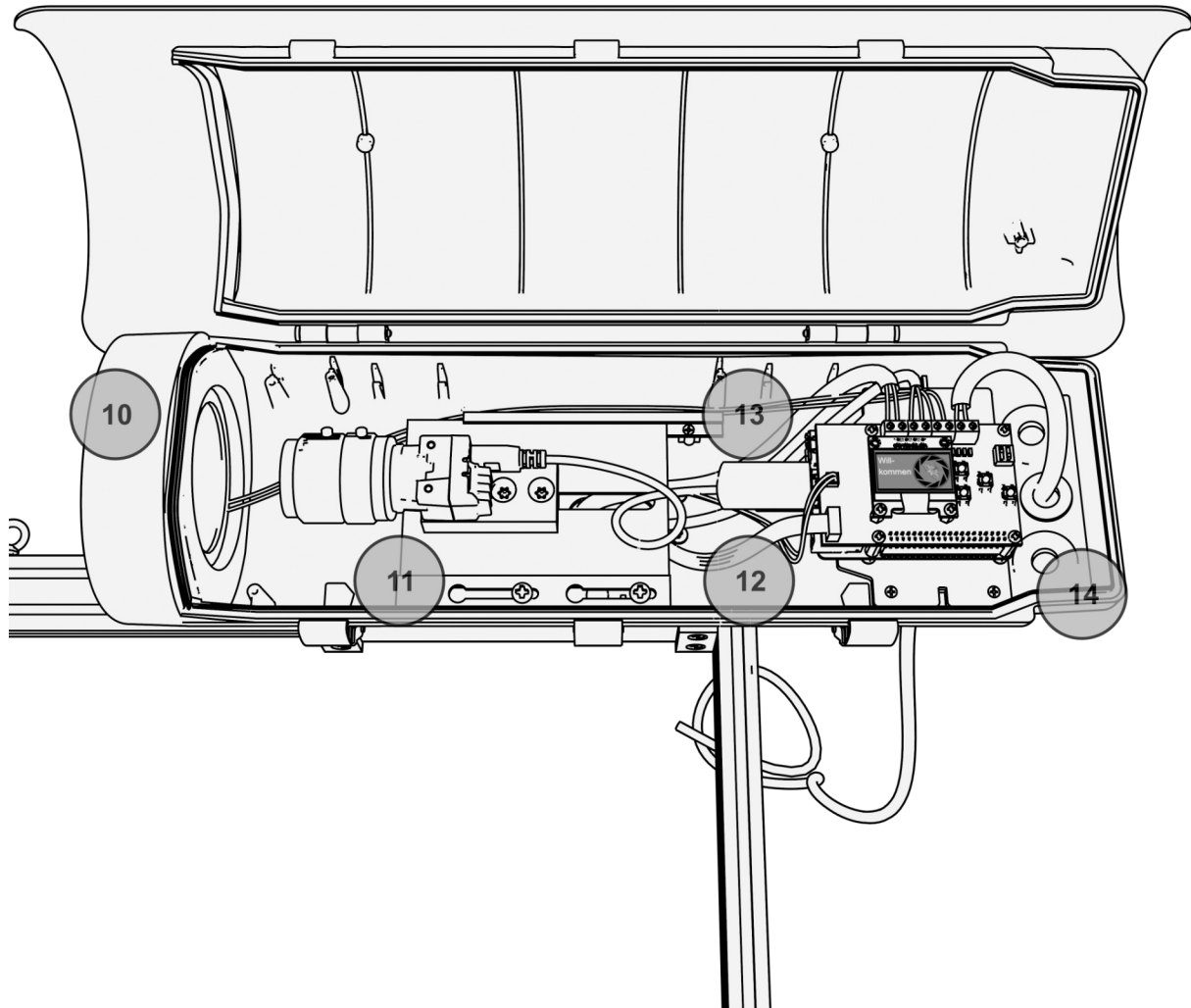

Compo-
nents

- | | | | |
|----|--|----|---------------------------------|
| 10 | Glass pane with heating | 13 | USB stick |
| 11 | Camera and lens | 14 | electronics with User interface |
| 12 | USB Y-cable and sensor cable | | |

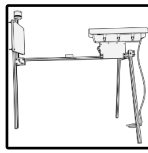

3.3 Details

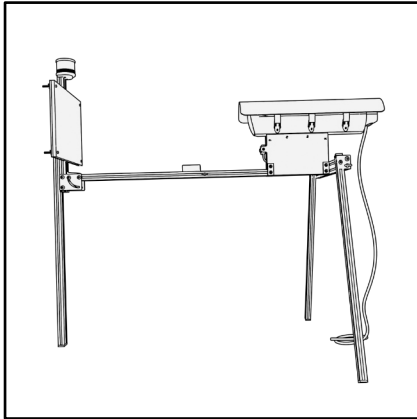

Rack

The rack consists of a front leg (left) with UV lamp, screen and hinge. On the right-hand side is the camera housing with spotlight above the rear pair of legs.

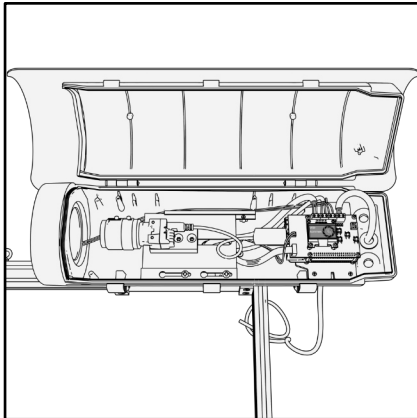

Camera housing

The camera housing contains the camera assembly, including the lens and control electronics. When the camera housing is open, it is possible to interact with ARNI via the user interface and maintain the memory.

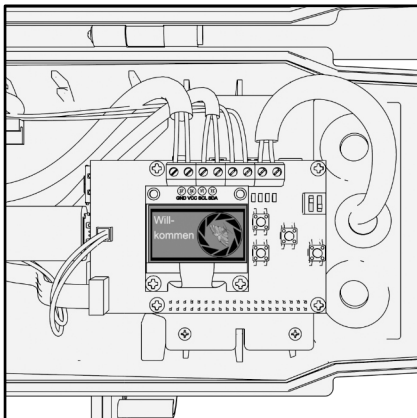

User interface – display

The user interface provides a black-and-white OLED panel for interacting with ARNI.

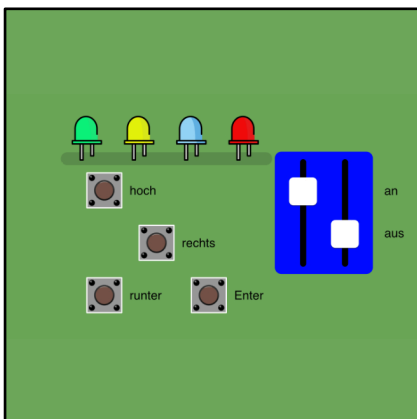

User interface – buttons

There are 4 buttons to the right of the OLED panel:

Up, down, right, enter

The on/off switch has two channels.

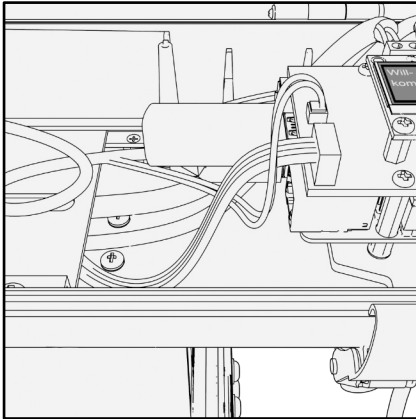
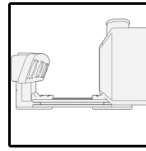
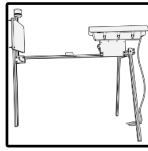

Connections on the Raspberry Pi

A USB stick for data storage and the camera's [USB Y-cable](#) are connected to the Raspberry and the control board.

The sensor cable is also connected to the board with a broadband connector.

Compo-
nents

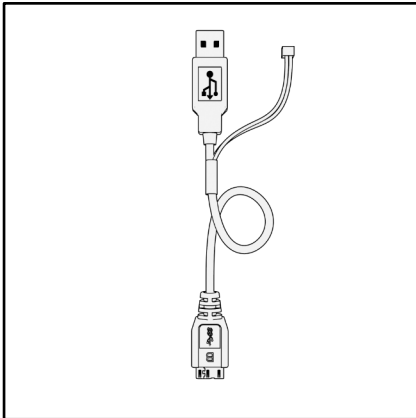

Modified USB Y-cable

All [Pro generations](#):

The USB cable has been modified: The power wires are separated from the data wires and connected to the board. The cable is shaped like a "Y".

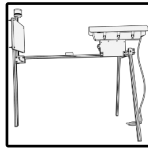

4 Setting up the ARNI

4.1 Tools

ARNI-Pro

- Torx 25 and Torx 30 screwdrivers
- Toothpick/small flat-head screwdriver
- UV glasses (not included)

Setup

4.2 Overview

To set up ARNI-Pro, a total of four steps must be performed:

- Screw on the pair of legs
- Attaching the support leg
- Raising the pair of legs
- Erect the support leg and unfold the screen holder

ARNI-Pro is shipped in two separate parts:

- Camera housing with folded screen and front leg attached
- Rear pair of legs, retracted

[A foam board is attached](#) to the screen. This part of the device must not be removed during installation.

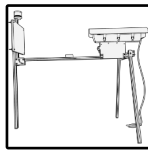

4.3 Assembly

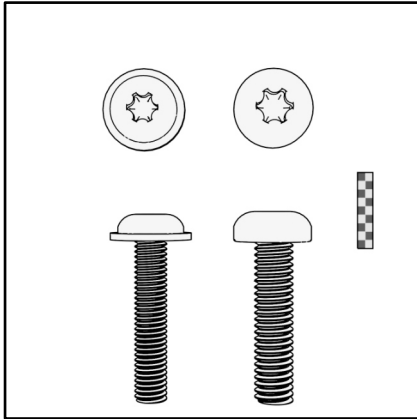

Screws

ARNI-Pro is assembled using screws. Some screws are never completely unscrewed. Each step specifies whether the screw must be completely unscrewed or only partially unscrewed.

Two types of screws are used: Torx 25 screws (left) and Torx 30 screws (right).

Setup

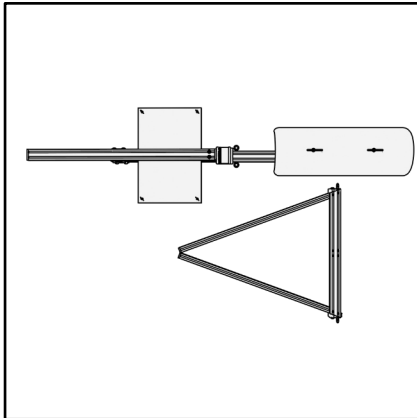

Step 1

Place both components on the floor.

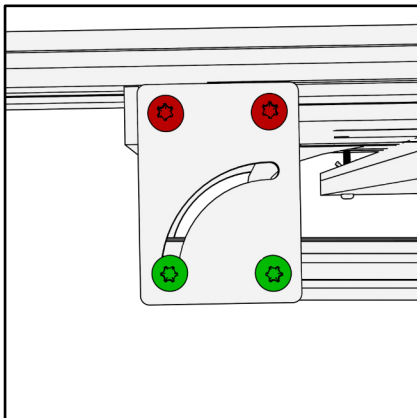

Step 2

There are four screws on each side of the hinge under the UV lamp. All four screws must be tightened securely. It is essential to check that the Torx 25 screws (marked in green) are tight.

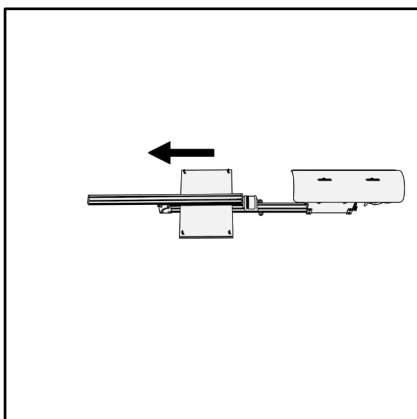

There is a movable aluminium profile above the UV lamp and shade. Move this carefully in the direction of the arrow. Make sure that the aluminium does not scratch the UV lamp.

Not applicable to devices sold by K2W Lights.

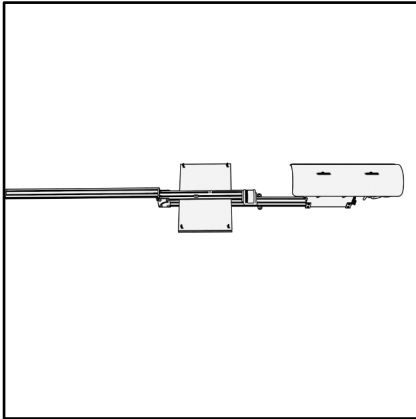
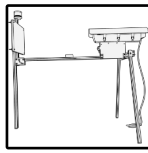

Step 4

The movable aluminium profile is now fully extended.

Not applicable to devices sold by K2W Lights.

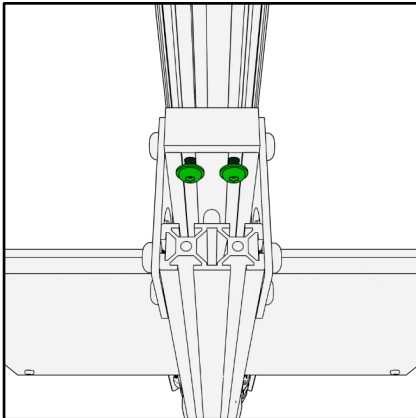

Tip

If the profile sticks slightly, the two Torx 25 screws (marked in green) on the underside inside the hinge can be loosened slightly. Never remove these screws completely. If these screws are tightened too much, the hinge can be loosened and folded down ([step 23](#) and [step 24](#)) to make these screws more accessible.

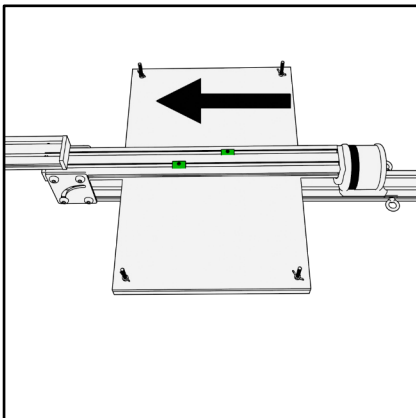

Step 5

Move the two slotted nuts (marked in green) in the direction of the arrow to the very end of the profile.

Not applicable to devices sold by K2W Lights.

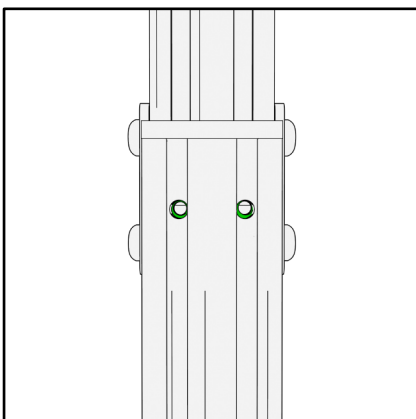

Step 6

Align the movable aluminium profile so that the two holes are exactly above the slotted nuts (marked in green).

Not applicable to devices sold by K2W Lights.

Setup

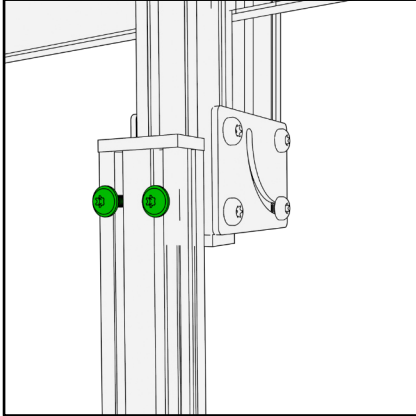
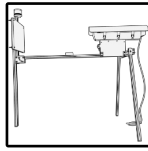

Step 7

Insert the two separate Torx 25 screws (marked in green) into the holes and screw them loosely into the slot nuts underneath.

Please find these screws in a small bag within the housing.

Not applicable to devices sold by K2W Lights.

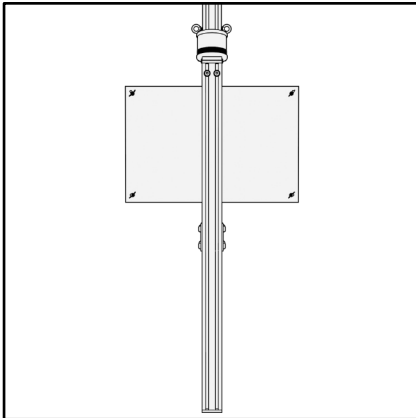

Step 8

Carefully slide the movable aluminium profile towards the UV lamp. Then tighten both screws securely.

Not applicable to devices sold by K2W Lights.

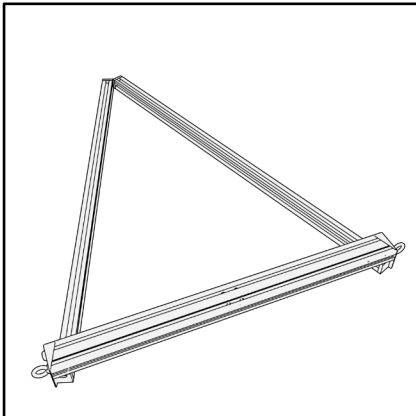

Step 9

Place the pair of legs on the floor so that the two aluminium profiles touch the floor and the middle profile is floating.

[Continue to step 15](#)

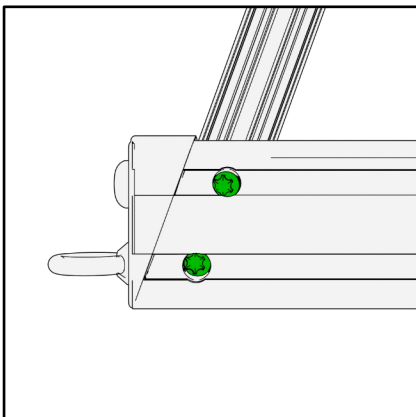

Step 10

There are a total of four screws in the corners of the pair of legs. The screws (marked in green) can be seen from above. Loosen these Torx 30 screws. Never unscrew them completely!

Setup

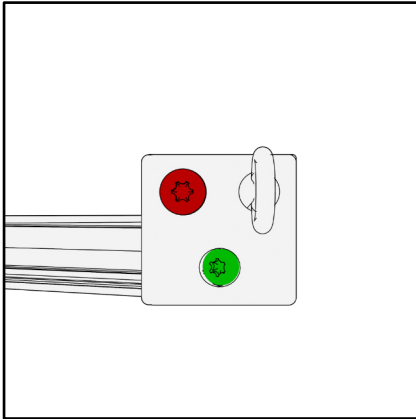
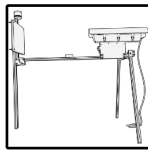

Step 11

Two further screws are visible from the outside. Loosen the Torx 25 screw (marked in green) by approximately half a turn until the leg can be moved.

Never loosen the other screw (marked in red).

Perform steps 10 and 11 on both sides of the pair of legs.

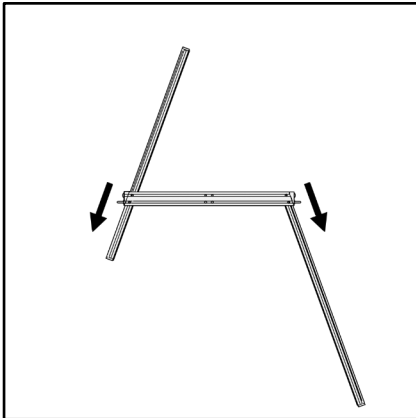

Step 12

Pull the two aluminium profiles in the direction of the arrow. To align ARNI straight in the field, these profiles can be moved to the desired position.

Once the legs are extended, first tighten the screw (marked in green) from step 11 and then the two screws from step 10.

[Continue to step 28](#)

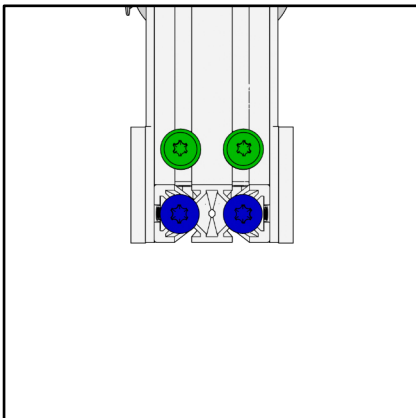

Step 13

There are 2 x 2 Torx 25 (marked in green) and Torx 30 (marked in blue) screws under the camera housing. Unscrew all screws.

[Continue to step 21](#)

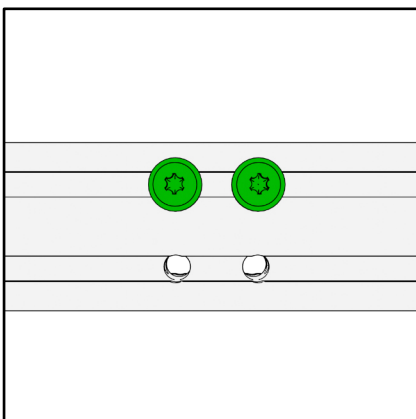

Step 14

Insert the Torx 25 screws from step 13 into the upper holes of the cross strut.

Setup

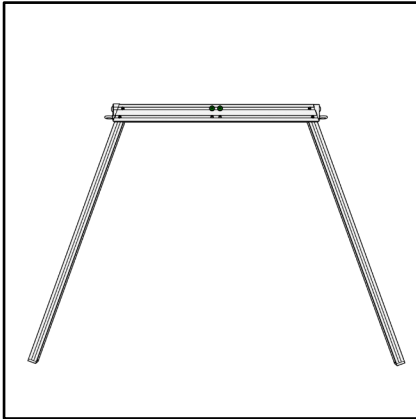
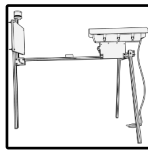

Step 15

The pair of legs is positioned as in [step 9](#): the two extended aluminium profiles touch the floor and the middle bar is floating.

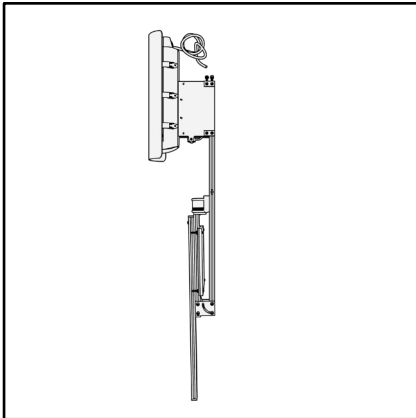

Step 16

Set up the frame vertically so that the camera housing is at the top. Make sure that the frame does not fall over.

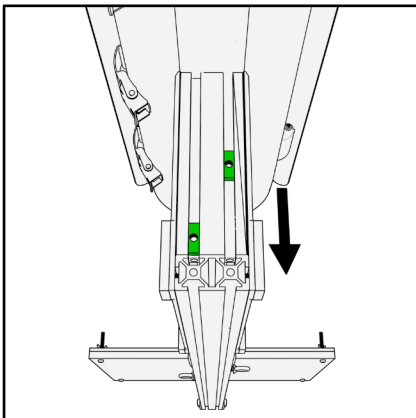

Step 17

Pull the two slotted nuts (marked in green) in the direction of the arrow until they stop.

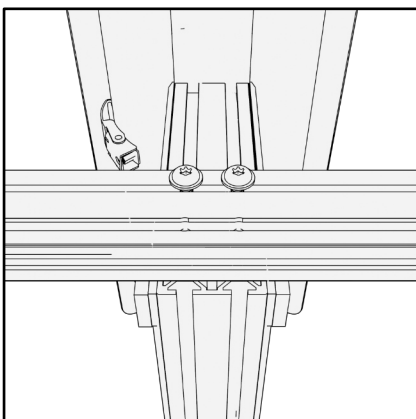

Step 18

Place the cross strut of the pair of legs on the upper end of the longitudinal strut so that the screws are in the same position as the slotted nuts in the frame.

Tighten the screws slightly – the pair of legs must remain movable.

Setup

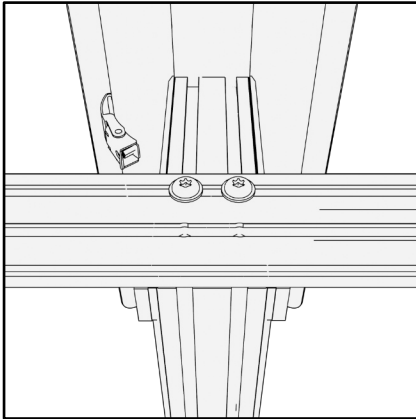
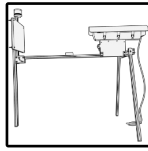

Step 19

Now carefully slide the cross strut away from the camera housing until the aluminium profiles on the side without screws are flush with each other.

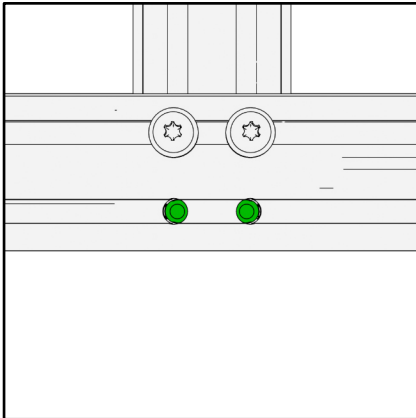

Step 20

The two holes without screws are located exactly above the threads in the longitudinal strut (marked in green).

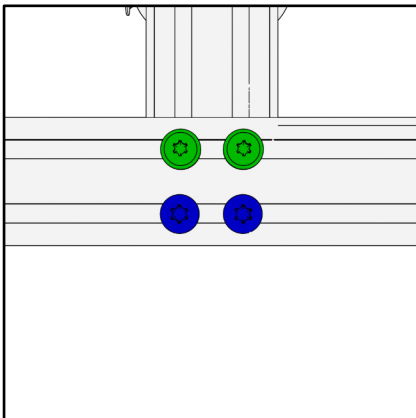

Step 21

Now insert the two Torx 30 screws from [step 13](#) (marked in blue) through the holes. Tighten all screws securely.

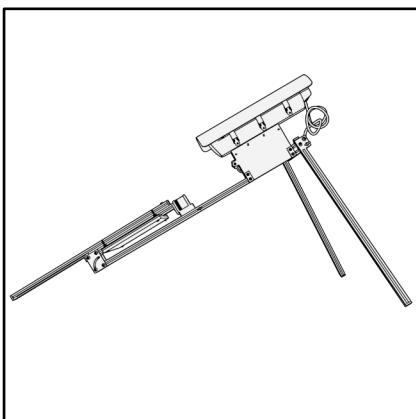

Step 22

Place ARNI-Pro back on the floor.

Setup

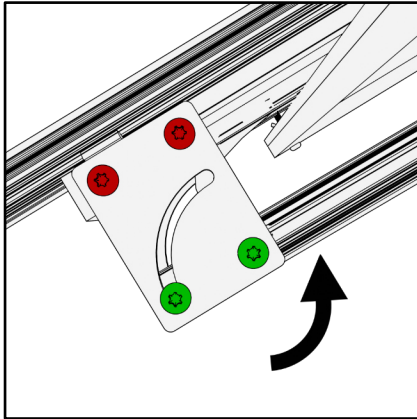
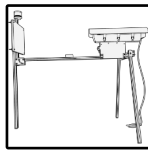

Step 23

There are four screws on each side of the hinge under the UV lamp. The Torx 25 screws (marked in green) must be loosened by a quarter turn in the direction of the arrow. Never unscrew the screws completely. Do not turn the screws marked in red.

Both screws marked in green sit on springs. Therefore, the screws must never be turned too loosely to prevent the springs from being lost. In addition, the hinge can slip if the screws are too loose.

Setup

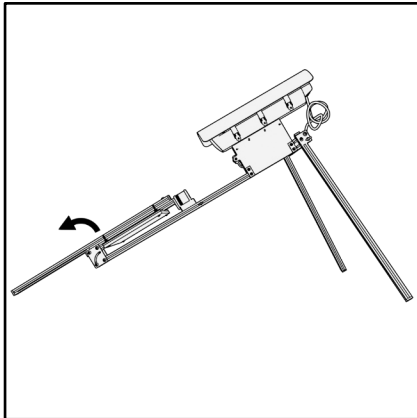

Step 24

Open the hinge completely and raise ARNI-Pro in the direction of the arrow.

[Back to step 4](#)

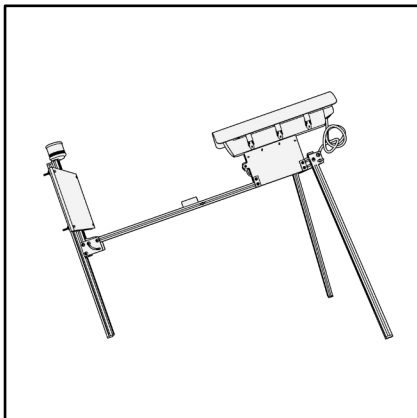

Step 25

Tighten the two screws from step 23 on each side again with a quarter turn (in the other direction).

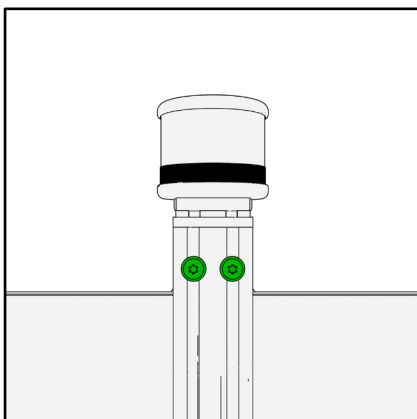

Step 26

Loosen the two Torx 25 screws (marked in green) under the UV lamp. Do not unscrew them!

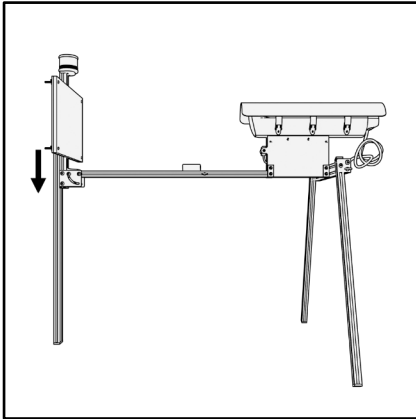
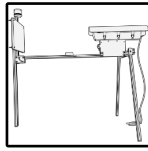

Step 27

Extend the support leg to the desired height.

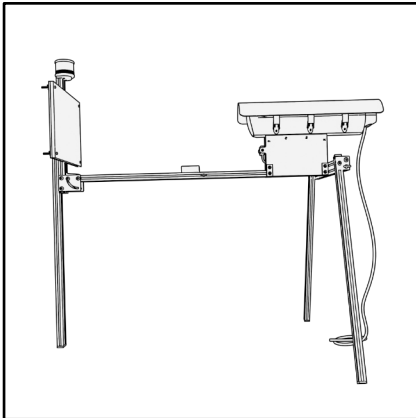

Step 28

When setting up, ensure that ARNI-Pro has a slight downward slope towards the canopy. This means that the pair of legs should be positioned slightly higher than the support leg. This allows condensation and rainwater to run off. On uneven ground, adjust the pair of legs to the surface as described in [step 12](#). The crossbar under the camera housing should be horizontal.

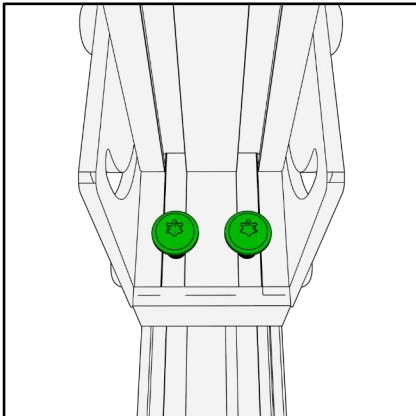

Step 29

There are two Torx 25 screws (marked in green) inside the hinge. Tighten these securely.

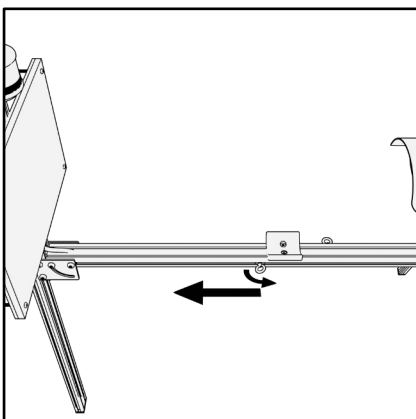

Step 30

ARNI has eyelets at the front end of the longitudinal strut and on the cross strut. Ropes (as with a tent) can be attached here to make ARNI-Pro wind-stable. In addition, the eyelets on the longitudinal strut can be carefully rotated (curved arrow). This allows them to be moved to the left and right to the desired position.

Setup

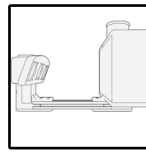
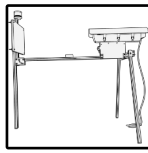

5 Power connection

5.1 Option A – Power grid

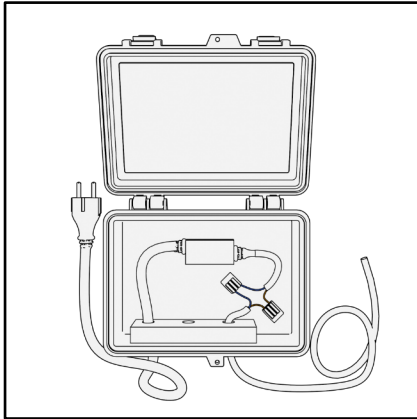

12 V DC with 5 A

A 60 W power supply unit should be used for mains operation. The standard values are 12 V/5 A. It should also be protected against the weather with a splash-proof (IP54) cable box. The box provides storage space to protect the earthed plug of an extension cable against splashing water.

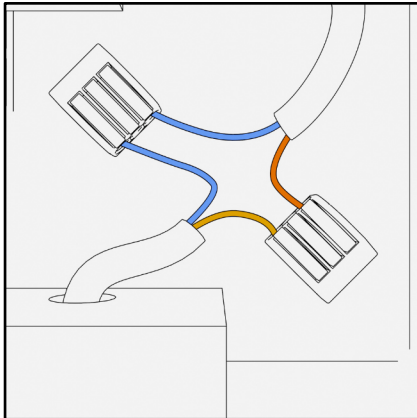

Cable cores

The connection to the power supply unit is made using WAGO terminals. Blue must be connected to blue (ground) and orange to brown (positive pole).

Power

Note

This power supply combination is not included in the standard scope of delivery of ARNI. Devices loaned through the LEPMON project can be equipped with a power supply.

A power supply unit must be purchased for devices sold by K2W Lights. A suitable power supply unit including a box, as otherwise loaned by the LEPMON project, can be purchased from Insects & Lights Jena (contact:info@gunnarbrehm.de).

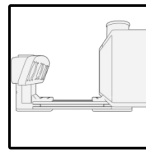
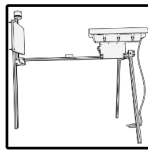

5.2 Option B – Solar panel and charge controller

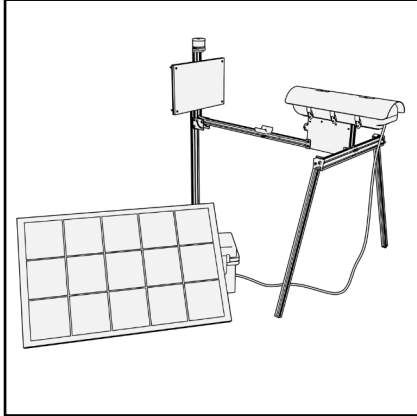

12 V DC with 5 A

ARNI can be operated independently with a PV system. This unit is not included in the standard scope of delivery of ARNI. Devices loaned out by the LEPMON project can be shipped with a PV box. Important: This box includes a charge controller, protective box and connection cables.

Battery (50 Ah, 12.8 V) and solar panel are not included! If necessary, please inquire about suitable models and batteries at info@gunnarbrehm.de



Charge controller

The PV units are equipped with a controller from Victron Energy and a converter. Detailed instructions for the control unit can be downloaded from the Victron Energy website:

<https://www.victronenergy.com/upload/documents/Manual-BlueSolar-PWM-Charge-Controller-LCD&USB-12V-24V-5A-10A-20A-EN-NL-FR-DE-ES-SE-IT.pdf>



Power

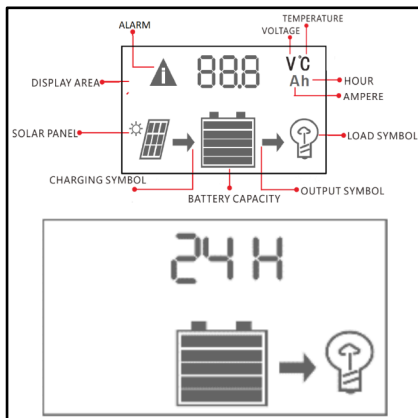

Power output

Set the operating mode to "24H" for commissioning/maintenance. Use "L" in recording mode. In this mode, the system only supplies power in the dark. Press the MENU button several times to display the controller information. If "24H" or "L" (or another load output) is shown on the display, press and hold MENU for a few seconds until the display/number flashes. You can now scroll through the outputs using the up and down buttons on the controller and select one.

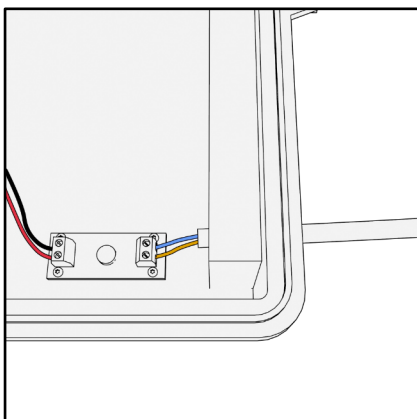

Connecting the wires

Depending on the model, the connection to the PV box is made either directly via Wago terminals or to a converter. To do this, the cable ends from ARNI must be tightened securely in the converter using a flat-head screwdriver. The brown wire of the cable from ARNI is screwed opposite the red wire (positive pole), and the blue wire opposite the black wire (ground).

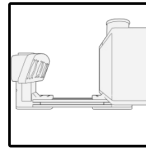
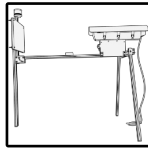

5.3 Protection against deep discharge

[Pro Gen 4](#), [CS Gen 1](#) only:

ARNI has integrated protection against deep discharge to protect the [battery](#). This threshold is 9.7 V input voltage.

ARNI measures the current regularly. Nevertheless, it may switch off without prior warning.

If the battery charge level is too low (output voltage below 9.7 V), ARNI cannot be switched on. In this case, follow the instructions for the battery and charge it.

Power

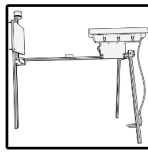

6 Opening/closing the camera housing

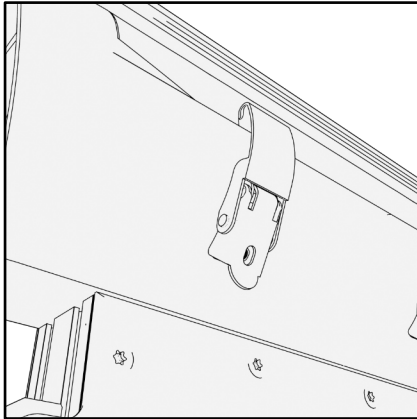

The camera housing has a hinge on the right-hand long edge (viewed from the camera) and snap locks on the left-hand side. These snap locks are located under the sun visor.

The opening and closing procedure is shown for [Pro Gen 3](#). The procedure is the same for [Pro Gen 4](#).

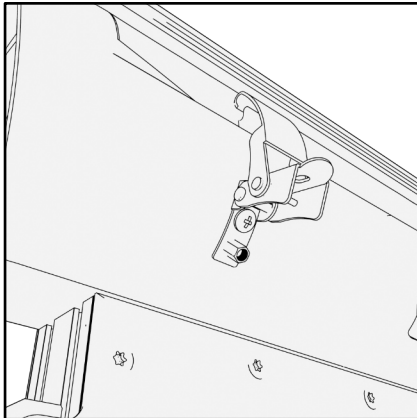

Opening

To release the snap locks, carefully press the handle upwards. This releases the barb from its counter bearing and allows it to be moved around it. Once all three locks have been released, the cover can be lifted upwards.

Start

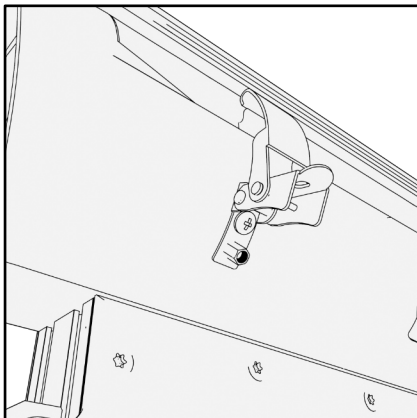

Closing

Carefully lower the lid. When the seals make contact, check that no cables are trapped. Carefully place the three hooks over the counter bearing. Then carefully press the three handles down one after the other.

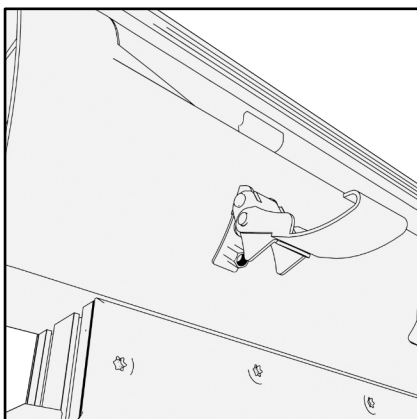

Caution

When opening the camera housing, check for insects under and between the snap locks.

Do not open the camera housing in the rain!

When closing the camera housing, it is essential to ensure that no cables are trapped.

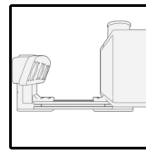
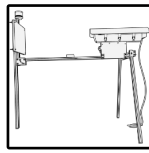

7 Switch on

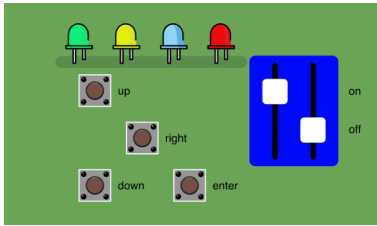

User interface with four buttons, four control LEDs, and the on/off switch (OLED panel not shown).

The buttons are small. Use a toothpick or small screwdriver (included) to move the controls. Never use a twig or tool that is too coarse to operate the buttons!

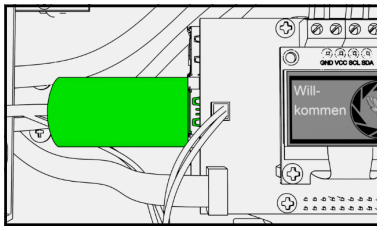

Insert an empty USB stick (green) with at least 256 GB storage capacity into the USB port via the [USB Y-cable](#).

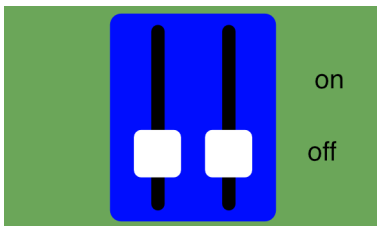

[All ARNI variants](#) are switched off when both switches are set to 'off'.

Start

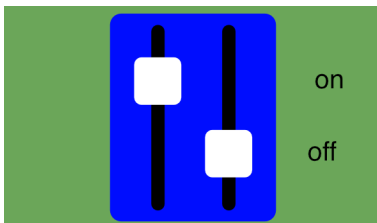

First, switch the left on/off switch to 'on' (up). The green control LED will start flashing and the LEDs on the Raspberry Pi (not the control LEDs next to the on/off switch) will light up.

ARNI is in continuous operation and also consumes power during the day.

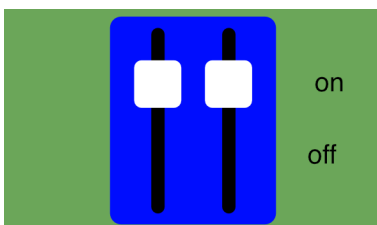

[Pro Gen 4](#), [CS Gen 1](#) and for [solar powered](#) operation of these generations:

set the right switch to 'on'. This activates the ARNI's power-saving mode and it consumes only minimal power during the day.

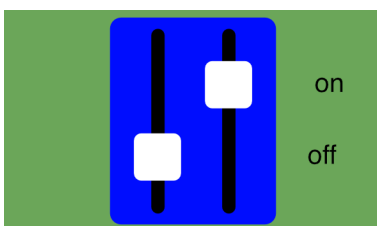

When switched off on the left and on on the right, the ARNI cannot be operated.

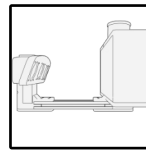
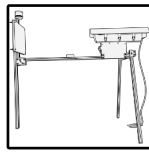

8 Start sequence

8.1 Control software for the Raspberry Pi

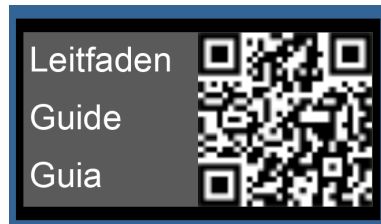

During the start-up sequence, ARNI first refers to the instructions (this document). The QR code displayed can be scanned with a mobile phone to download it from the project website:

<https://lepmon.de/en/arni-manual/>

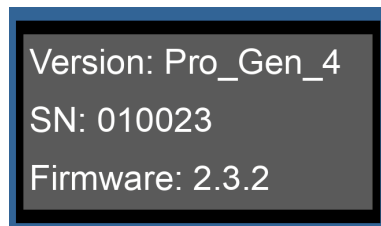

ARNI displays important device data:

- The device version and generation
- Unique identification/serial number (SN)
- The current firmware version

See also the [‘please select’](#) error if this information is incorrect



After a short time, ARNI displays the start sequence. The LEPMON logo appears. If ARNI does not display anything and the red control LED flashes repeatedly, there is a fault with the display. The display is plugged in and secured with a screw. Check this plug connection and restart manually.

Start

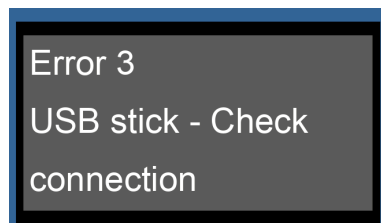

If no USB stick has been inserted or if it is faulty, ARNI will display [error 3](#) as soon as it starts up. The stick can be reinserted. If this is successful, ARNI will continue with the start sequence. The red indicator LED will light up a total of up to ten times. Each time it lights up, ARNI will attempt to access the memory.

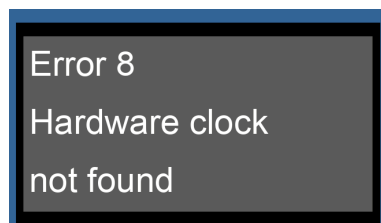

If there is a problem with the hardware clock, ARNI will indicate this (repeatedly) in the start sequence. The time can only be set in the menu on the Raspberry itself. However, this time quickly becomes inaccurate.

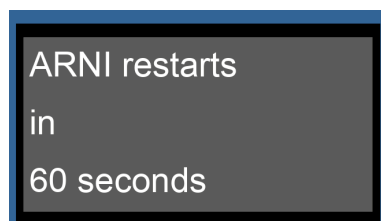

If one of these problems persists, ARNI will start a countdown to restart. Wait for this countdown to finish and let ARNI restart on its own. Reinsert the USB stick during the restart.

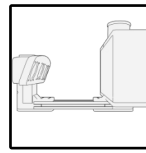
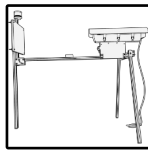

8.2 Control software for 'LEPMON_solar'

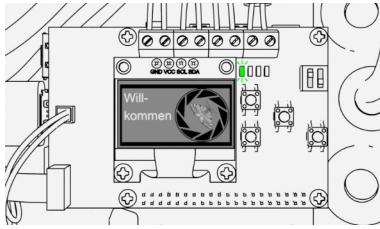

[Pro Gen 4 and CS Gen 1](#) ARNIs feature a power-saving mode control. This software is managed by a separate controller. The controller indicates its status via the flashing of the green LED.

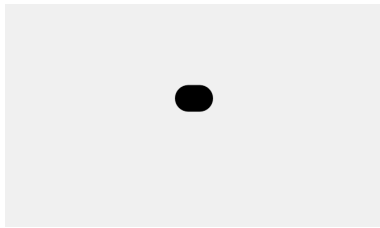

Flashing pattern: 1 short flash

Duration: 10 seconds

Solar control software version

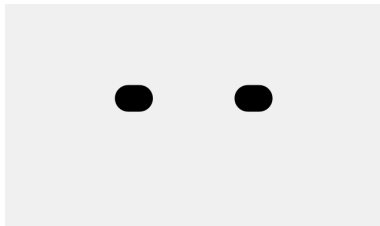

Flash pattern: 2 short flashes

Until the Raspberry Pi is switched off

Requirements for the Raspberry Pi

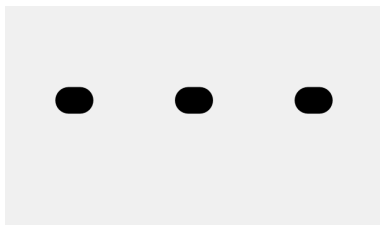

Flashing pattern: 3 short flashes

Until RTC alarm

Waiting for timer

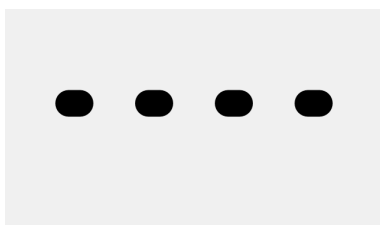

Flashing pattern: 4 short flashes

Until the Raspberry Pi is active

Waiting for the Raspberry Pi

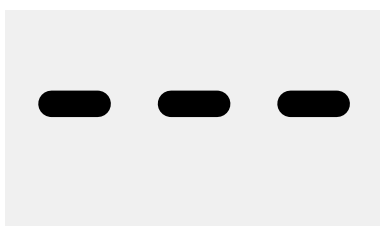

Flashing pattern: 3 long flashes

Duration: 15 seconds

Wait for a proper shutdown

Start

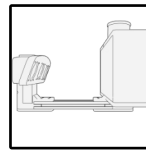
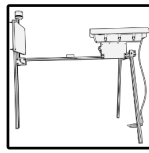

9 Input menu

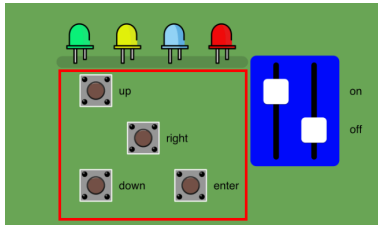

User interface with four buttons, four control LEDs, and the on/off switch (OLED panel not shown).

The input menu is navigated using four buttons: **up**, **down**, **right**, and **Enter** (red box).

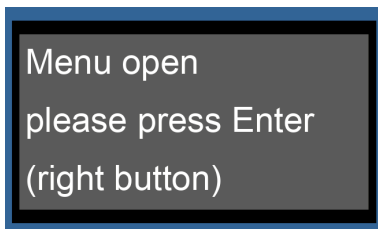

After the start sequence, you have the option of opening the input menu. To do so, press **Enter** within the next 10 seconds. If nothing is pressed during this time, ARNI will start recording mode and wait for the first recording.

If you miss the input menu, ARNI must be restarted.

If you accidentally enter the same setting twice within a menu item, you can easily correct this by either adjusting the setting using **up** or **down** or by repeatedly pressing **right** to select the desired position again. If you press **Enter** accidentally or too often, you can return to the previous menu item by pressing **right**.

Menu hidden

The input menu consists of three components: "hidden menu," "visible menu," and "diagnostics," and allows access to various settings:

Hidden menu: Language, Focus, Firmware update

Visible menu: Power supply, Delete USB stick, Windshield heating, Date and time, Latitude and longitude including LEPMON code

Diagnostics: Status messages for all electronic components

When it comes to the settings options, ARNI indicates when it is waiting for input from the user. The blue indicator LED lights up. When the blue indicator LED is not lit, ARNI displays information.

The coordinates only need to be entered the first time or when changing location. These can be determined using an external GPS device or a smartphone and a navigation app. ARNI uses the WGS-84 format.

In addition to the coordinates, ARNI uses an abbreviation (LEPMON code) to assign the recorded data to the location. This code consists of the state and county. It is essential that this is set correctly.

The date and time must be reset each time the device is started manually or the memory is changed. This is necessary because the device's internal clock may deviate from the actual time over time.

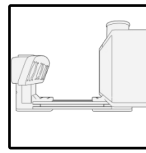
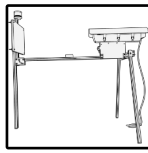

10 Hidden menu

10.1 Change language

Input menu
opened

When the input menu is opened with **Enter**, ARNI displays a message. If you press **down** during this display, the language menu opens.

Language: English
change?

▲ = yes ▼ = no

ARNI displays the language currently in use. In addition, either press **up** to select a new language or press **down** to exit the language menu.

Deutsch ▲
English →
Español ▼

When the **up** is pressed, ARNI displays the supported languages. By selecting:

up = German

right = English

down = Spanish

the new language is selected and displayed with an "x".

Menu
hidden

Input menu
opened

The language menu is closed, but can be reopened by pressing **down** again.

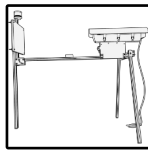

10.2 Focus

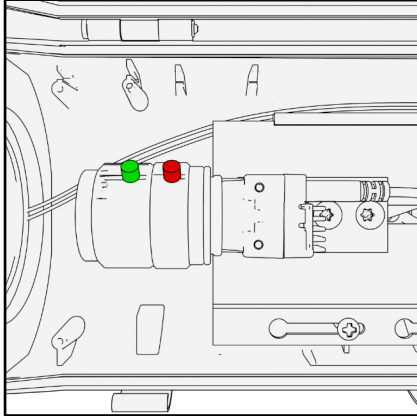

Not [CS Gen 1](#):

ARNI has a fixed focus lens. The focus is close to 0.7 m. If the focus shifts and ARNI produces blurry images, it will issue a [warning in the log file](#). The focus can be readjusted without additional tools. To do this, loosen the small screw at the front end (marked in green) of the lens by hand.

Never unscrew the screw completely! Do not turn the rear red screw!

The screw marked in green is partially invisible, depending on the rotation of the lens. Hold the rear part firmly when rotating the front part of the lens between 0.5 m and 1 m.

Input menu
opened

When the input menu is opened with **Enter**, ARNI displays a message. If you press **right** while this message is displayed, the focus menu opens.

Menu
hidden

Focusing:

▼ = local

unten drücken, um fortzufahren, oder **rechts**, um abzubrechen.

Cancel focusing:
press Enter
and hold

If the menu has opened accidentally, you can cancel it.

To do this, **press and hold the Enter**. This might take up to one **minute**.

Determine exposure
for focusing
255; 100 ms; 10

ARNI runs through a series of exposures and attempts to find the optimal exposure. To do this, the illuminator is switched on. ARNI captures frames and calculates their average brightness (e.g., 150.7) and displays the current exposure time (140 ms) and sensor sensitivity (gain 4).

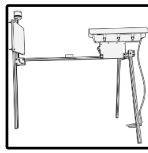

Exposure
determined

Once a good exposure has been found, ARNI will notify you.

Note: If one of the following displays appears permanently and without change, ARNI is “frozen.” It must be restarted and focusing must be restarted.

Focusing
until sharpness
maximum reached

ARNI starts recording frames again. ARNI calculates the Gaussian blur of each frame. During recording, the blue control LED is off and the lens must not be adjusted! The OLED panel also indicates when the lens (green screw area) can be focused/rotated.

turn focus
ring (0.5 - 1 m)
old:120 - new:100

When “now turn focus ring” is displayed, focus/turn the lens (area of the green screw). The focus of ARNI is between 0.5 and 1 m. The blue control LED lights up. First turn in one direction.

Menu
hidden

Taking test image
do not turn
old:120 - new:100

As soon as the display changes to “Record test image, do not turn”, do not rotate the lens. The blue indicator LED is off.

Image is sharper
turn further
old:120 - new:134

After evaluating the frame, ARNI indicates whether the focus has improved or not. To do this, note the values for “old” and “new.”

If “turn further” is displayed, turn in the same direction the next time “now turn focus ring” is displayed.

Image is blurrier
turn back
old:120 - new:103

When “turn back” is displayed, turn in the opposite direction the next time “now turn focus ring” is displayed.

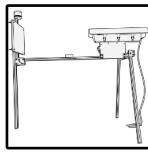

Image unchanged
no change
old:120 - new:120

If “no change” is displayed, turn the focus ring in the other direction the next time you hear “now turn focus ring.” If this display is reached continuously, the focus is set.

Focusing ended
by user

The focus menu can be closed by the user. To do this, hold down the **Enter**.

Tighten the screw marked green on the lens again. Do not change the alignment of the camera under any circumstances.

Input menu
opened

The focus menu is closed, but can be reopened by pressing **right**.

Menu
hidden

Camera - Check
cable connection
n/91

If an [error occurs in the communication between the camera](#) and the Raspberry, ARNI indicates that the cable connection must be checked. The Raspberry attempts to access the camera and displays the number of attempts (n).

Camera overloaded
focusing not
finished

If the camera has been unable to create frames multiple times, it is overloaded.

continue focusing
after restart

ARNI restarts and reopens the focus menu, as it can be assumed that the lens has not yet been fully focused.

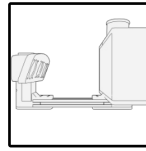
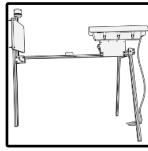

Emergency stop
Visible LED
after 5 minutes

If the focus menu is open for too long and the spotlight stays on for too long, there is a risk that the spotlight's LED will burn out. ARNI therefore switches off the spotlight in an emergency.

Focusing loop
starts

[CS_Gen_1](#) only:

ARNI starts the focus loop automatically.

Focusing ended
Diopters old: 4.98
Diopters new: 5.1

After completing this loop, it displays the newly found focus value in diopters.

Menu
hidden

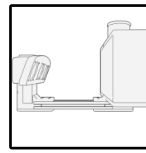
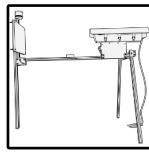

11 Visible menu

11.1 Power supply, storage deletion, heating

Input menu
opened

When **Enter** is pressed, ARNI indicates that the input menu is open. If no button is pressed during this display, ARNI switches to the visible menu.

Power supply:
▲ = Solar → = back
▼ = Grid

ARNI can be operated with a solar panel with charge controller (in a splash-proof box) and battery or power supply. Depending on the operating mode, select **up** for solar panel and charge controller or **down** for a power supply. Use **right** to return to the hidden menu.

Power supply
Solar

ARNI displays the selected power supply.

Erase USB data?
▲ = yes → = back
▼ = no

Images already uploaded to [LAUP](#) can be deleted from the USB stick. ARNI provides a function for this purpose: ARNI asks whether the USB stick should be deleted. This will permanently delete all folders, images, and files from previous recording sessions that are still stored on the USB stick.

Erasing USB data
please wait
n/x

If the question is confirmed with “yes” (pressing **up**), ARNI deletes all previous recording sessions. Depending on the size of the memory, this may take a moment. ARNI displays the progress with n = number of folders already deleted and x = number of folders to be deleted.

USB data deleted

Once all folders have been deleted, ARNI will display a success message.

Note: This action cannot be undone.

Menu

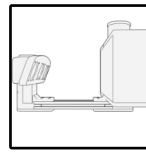
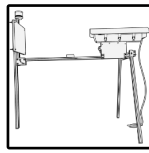

USB data
not deleted

If the question is rejected with “no” (pressing the down button), ARNI continues without deleting.

Heat window?
▲ = yes → = back
▼ = no

Only Pro_Gen_2; 3; 4:

ARNI has a heater around the glass pane. This can be switched on if there is moisture in the housing. Press **up** to activate. Press **down** to turn the heater off. Press **right** to navigate back to the USB stick delete function.

Heater on
for 15 min

When the heater of the front glass is activated, ARNI displays the message “Heater activated for 15 min” and switches it on after diagnosis and/or at the start of the recording run.

Heater remains
off

Alternatively, the heating remains switched off.

Menu

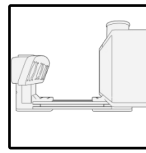
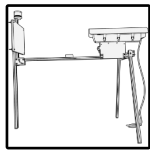

11.2 Setting the date and time

Date / Time:

▲ = update

▼ = confirm

First, the time must be checked. To do this, ARNI indicates that the current time can be confirmed with **down** or corrected with **up**.

2026-04-01 12:34:56

▲ = new → = back

▼ = ok

ARNI displays the current time and date. This continues until either this timestamp is corrected or confirmed. Alternatively, you can return to the windshield heating by pressing **right**.

Set date ▲

2025-12-19 →

x ▼

When pressed, ARNI displays "Set date." The second line shows the date in the format YYYY-MM-DD. The third line shows the position currently being edited with an x. The arrows symbolize the function of the buttons: **right** moves the x one place to the right. **Up/down** increase/decrease the corresponding digit. If the date is correct, confirm with Enter.

Menu

Each individual digit of the year, month, and day can be changed by pressing **up/down** to increase or decrease the value by 1. This is done from left to right:

Once the first digit has been set correctly, it is saved by pressing **right**. Now you can change the second digit. In the third line, an "x" indicates the currently selected position. Press **right** again to save this and enter the third digit, etc. When you reach the last digit, you can save the displayed value for the date by pressing **Enter**.

If a correction is necessary, press **right** until the incorrect digit is reached. Pressing the **up/down** buttons again allows you to make the correction. Once all digits are correct, press **Enter** to save the displayed value.

If ARNI already displays the correct date, it can be saved by pressing **Enter**.

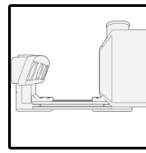
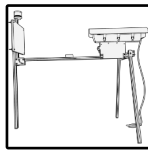

Set time ▲

12:34:56 →

x ▼

Entering the time follows the same pattern as for the date. ARNI displays “Set time” and below that the internal time in HH:MM:SS format at the beginning. In the third line, “x” marks the current position. The arrows indicate the key function: **right** moves the x one place to the right. **Up/down** increase or decrease the corresponding digit. When the time is correct, confirm with Enter.

Error 8

Hardware clock
not found

If ARNI already displays [error 8](#) here, there is a problem with the hardware clock. Only the Raspberry's clock can be set, but it becomes inaccurate after a short time.

Invalid input!
try again

ARNI only allows the range 1-31 for the day and 1-12 for the month. The year can be left blank, but ARNI will display an “invalid entry” message if the year is not between 2025 and 2035. In this case, ARNI will automatically restart the time entry process.

Warning: Only
Raspberry time
updated

Only the Raspberry's clock can be set, but it becomes inaccurate after a short time.

Tip:

Set the displayed time to the next full minute and press **Enter** when the current minute reaches :59.

Note:

ARNI uses the time zone determined from the [coordinates entered](#) to determine whether it needs to set the clock forward or backward. This always takes place [after the experiment](#) on the relevant night in spring and fall.

Menu

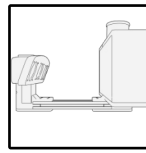
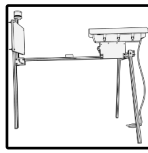

11.3 Enter GPS coordinates

Coordinates:

▲ = update

▼ = confirm

ARNI displays the currently set location coordinates and allows the user to reset them with **up** or confirm them with **down**. In addition, **right** can be used to navigate back to the date and time.

N-S: 11.23456789

E-W: -123.45678

▲ new ▼ ok →back

The display remains visible until the coordinates are confirmed or corrected.



ARNI uses WGS84 (World Geodetic System 1984) as its reference system. It uses decimal notation.

The coordinates can be determined using a map service provider in a smartphone app, for example.

Menu

Google Maps © is shown in the example. The red box shows the location coordinates in decimal format. Alternatively, the coordinates can also be determined in advance and set in ARNI.

Gesetzte Markierung

In der Nähe von Vor dem Neutor,
07743 Jena

1 min

Route Start Speichern

In der Nähe von Vor dem Neutor,
07743 Jena

(50.9241077, 11.5837992)

Entfernung messen

Please
enter hemisphere

First, the hemispheres must be entered for north/south or east/west.

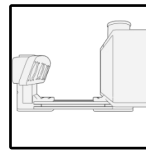
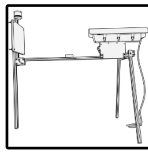

▲ = North

▼ = South

ARNI first queries the northern/southern hemisphere:

Up selects the northern hemisphere and **down** selects the southern hemisphere.

Germany: "North"

▲ = East

▼ = West

Next, the east/west hemisphere is queried:

Up selects the eastern hemisphere and **down** selects the western hemisphere.

Germany: "East"

Latitude (N-S): ▲

51.3456789 →

x ▼

First, ARNI displays "Latitude (N-S)" and the currently set latitude. ARNI remembers the hemispheres from the previous step and displays a minus sign for "South." If all positions are correct, the latitude can be saved by pressing **Enter**.

Longitude (E-W): ▲

-123.45678 →

x ▼

Now enter the longitude (E-W). Here too, ARNI remembers the hemisphere and displays a "minus" for west. As soon as the longitude is confirmed with **Enter**, ARNI saves the current position. The next time it is started, it displays the latitude and longitude values again. If ARNI's position is unchanged, you can press **Enter** directly under "Coordinates."

Coordinates

saved

ARNI indicates that the save was successful.

Invalid longitude!

Please choose
a valid value

If a longitude greater than 180 or less than -180, or a latitude greater than 90 or less than -90 is entered, ARNI will indicate that this value is invalid.

Menu

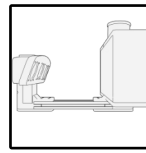
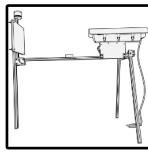

Checking country/ province of entered coordinates

ARNI has a function that checks the country and province/state of the coordinates entered. This serves as a safety measure for the user. It has no influence on the LEPMON code. In addition, inaccuracies in the determination may occur in the border area between two provinces.

Country: Germany
Province: Thuringia
▲ = new ▼ = ok

ARNI displays the country and province. Confirm with **down** and continue, or correct the coordinates entered with **up**. If the province cannot be determined, ARNI displays [error 16](#).

Menu

When entering latitude and longitude, each individual digit can be changed by pressing the **up/down** to move up or down one position. This is done from left to right:

Once the first digit has been set correctly, it is saved by pressing **right**. Now the second digit can be changed. In the third line, an "x" indicates the currently selected position. Pressing **right** again saves this and allows you to enter the third digit, etc. When you reach the last digit, you can save the displayed value for latitude or longitude (press **Enter**).

If a correction is necessary, press **right** until the incorrect digit is reached. Pressing **up/down** again allows you to make the correction. Once all digits are correct, press **Enter** to save the displayed value.

If ARNI is already displaying the correct coordinates, they can be saved by pressing **Enter**.

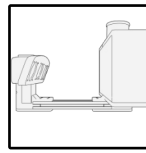
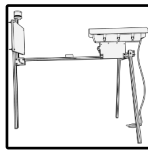

11.4 Enter LEPMON code

LEPMON-Code:

▲ = update

▼ = confirm

Once the coordinates have been entered, the LEPMON code can be set. The code is a location stamp consisting of the country, province, and city. The city follows the region's license plate code.

If ARNI is set up in a different region, this menu must be accessed (press up).

LEPMON-CODE

is default

please change

If no LEPMON code has been entered yet, ARNI displays a prompt.

Province: TH

District: J

▲ = new ▼ = ok

ARNI displays the currently set LEPMON code. This code can be confirmed by pressing **up** or reset by pressing **down**. A list of [available codes](#) is provided at the end of this document.

When **down** is pressed, ARNI prompts for the state, province, and city codes.

Menu

Select country:

Germany

right = confirm

ARNI prompts you to enter the country. Use **up/down** to scroll through the list of countries until the destination country is displayed. Then confirm with **right**.

Select province:

TH

right = confirm

ARNI prompts you to enter the province/state. Use **up/down** to scroll through the list of provinces/states until the target province is displayed. Then confirm with **right**.

Select district: J

1. right = confirm

2. Enter = finish

ARNI prompts you to enter the district. Select the abbreviation for the region's license plate here. Use **up/down** to scroll through the list of license plates until the desired district is displayed. A list of available license plates can be found at the end of this document.

Then confirm with **right** and finish with **Enter**.

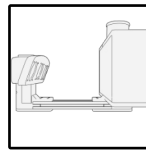
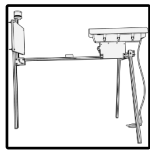

Selection
finished

The selection is now complete...

Germany
TH
J

...and ARNI displays the new LEPMON code.

(here, TH = Thüringen and J = Jena)

Code unchanged
continue

If the code is unchanged, ARNI continues normally.

Code changed
ARNI adopts
changes

When a new LEPMON code has been entered, ARNI applies it to the data already written for this run and logs this change. The input menu can be continued.

Menu

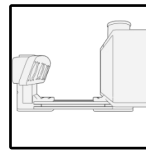
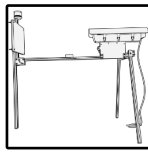

12 Diagnostics

12.1 Sensors

▲ = Start test run

→ = back

After the visible menu has ended, a test run can be started immediately with **up** or you can navigate back to the coordinates menu with **right**. ARNI will start the test run automatically after 2 minutes at the latest. ARNI tests all essential components and displays their status:

Light_Sensor

Status: OK

Wert: 171 Lux

- Brightness (ambient light)

Inner_Sensor

Status: OK

Wert: 22.8 °C

- Internal temperature (inside the camera housing)

Power_Sensor

Status: OK

Wert: 12.12 V

- Current meter (supply from ARNI)

Environment_Sensor

Status: OK

Wert: 22.8 °C

- Air pressure and humidity (ambient air)

Power_Sensor

Status: Fehler

Wert: ---

If a sensor cannot be found, its status is displayed as an error. ARNI initiates a series of accesses to the sensors so that, for example, the sensor cable can be checked.

Diagnostics

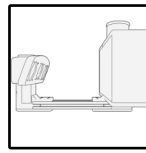
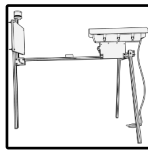

test sensors
again
waiting...

During the loop, ARNI displays the corresponding [error codes](#). In addition, the control LEDs light up during sensor access.

All sensors
present

If all problems have been resolved, ARNI displays a success message and shows all current sensor values.

Sensor still
missing
continue anyways

If access to one or more sensors fails, ARNI will inform you of this, but will continue with the diagnosis in the input menu.

Diagnos-
tics

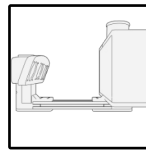
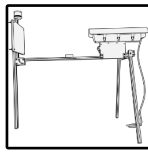

12.2 Camera

Camera test

ARNI is now testing the camera.

Camera test
Camera is
initializing

To do this, it is initialized...

Camera test
Camera is
powering on

... and switched on.

Dim
UV lamp
up

Both lamps dim up.

Diagnos-
tics

UV



Never look directly into the UV lamp! Danger to eyes!

The radiation is largely invisible and only a faint violet color is visible. Maintain a distance of at least 50 cm from the UV lamp during operation!

Dim
UV lamp
down

After a test image has been captured, the lamps immediately dim.

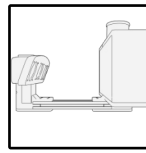
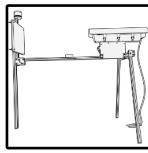

Image
saved

When the camera has been activated and the image has been successfully saved, ARNI will confirm this.

Camera test
successful
finished

The camera test has been successfully completed.

Camera - Check
cable connection
n/91

If an [error occurs in the communication between the camera](#) and the Raspberry, ARNI indicates that the [USB Y-cable](#) connection must be checked. The controller attempts to access the camera and displays the number of attempts (n).

Camera test
Access
failed

If 91 attempts were unsuccessful, access has failed. ARNI initializes the camera again.

Diagnosis

Camera test
camera not
available - restart

If the camera cannot be accessed even after multiple initializations, ARNI will restart. After restarting, open the input menu again.

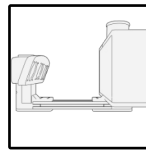
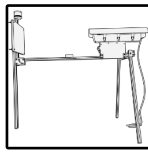

12.3 USB and twilight times

USB storage
total: 255.9 GB
available: 255.8 GB

The memory device that was inserted into the USB slot before switching on is then queried. The values are displayed in gigabytes (GB). The capacity and the amount of free storage space available are determined.

USB storage
OK

If the memory is OK, ARNI displays "OK."

USB storage
not detected
check connection

If the memory is not recognized, ARNI displays a warning.

USB storage
almost full
delete

If the USB stick has less than 16 GB capacity or the USB stick is not readable, ARNI will indicate that the stick has not been recognized.

ARNI will restart after 5 seconds. This allows another stick to be inserted for a new diagnosis.

Diagnosis

Sunset: HH:MM:SS
Sunrise: HH:MM:SS

Finally, ARNI displays the sunrise and sunset times for the location in HH:MM:SS format.

The sunrise time should always be earlier than the sunset time. Check the coordinates if necessary.

Test run finished
close
lid

The diagnosis is complete. ARNI reminds you to close the lid.

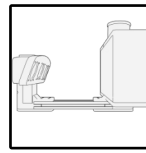
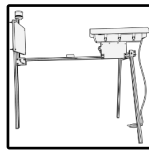

Test run finished
adopting new
LEPMON-Code

If a new LEPMON code has been entered, ARNI now applies the changes and logs [them](#).

Starting in
HH:MM:SS

After the menu has ended or if the menu has not been opened, ARNI waits until the first recording if the night has not yet begun. The remaining time is displayed as a countdown for 2 minutes. "Start in: HH:MM:SS." After that, the display goes blank and ARNI is in "sleep mode."

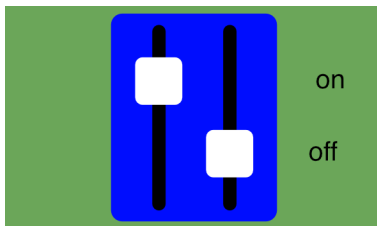

[Pro Gen 3](#) only: leave the power switches in the "Adjustment" position. This means that the left switch on the left channel is up and the right switch is down.

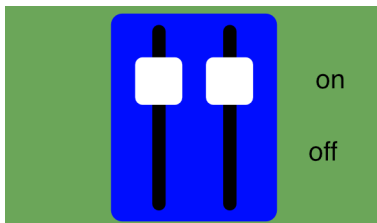

[Pro Gen 4](#) and [CS Gen 1](#): the power switches can be set to power-saving mode. To do this, both switches must be set to 'on'.

Diagnosis

UV



At the beginning of the night, ARNI switches on the UV lamp.

Never look directly into the UV lamp! Danger to your eyes!

The radiation is largely invisible and only a faint violet color is visible. Keep a distance of at least 50 cm from the UV lamp during operation!

ARNI restarts
in
60 seconds

At the end of each night, ARNI displays the last minute of activity before it stops monitoring and restarts.

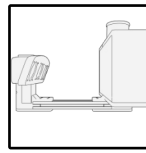
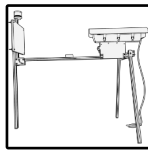

13 Maintenance

13.1 During the season

ARNI must be visited approximately every 14 days to change the storage medium (always) and update the time (always). Other parameters (geographical coordinates and LEPMON code) only need to be adjusted if the location is moved to another site (only in consultation with the LEPMON team).

Steps:

1. Switch off ARNI using the on/off switch. The system is switched off when none of the lights on the Raspberry next to the on/off switch are lit.
2. Remove the USB stick.
3. Insert the second, empty USB stick provided for this purpose.
4. Restart ARNI by pushing the on/off switch again.
5. Solar systems only: Set the [power output](#) to "24H".
6. Repeat the steps described above starting in [chapter 7](#). The location of ARNI is almost never changed. Therefore, press **Enter** directly after setting the latitude and longitude and always [reset the time](#).
7. Upload ARNI's images to LAUP: <https://lepmon.de/annot8/login> Detailed step-by-step instructions are available on the project website: <https://lepmon.de/annot-8-das-lepmon-annotierungstool/>
8. Solar systems only: Set the [power output](#) to "L".

13.2 After the season

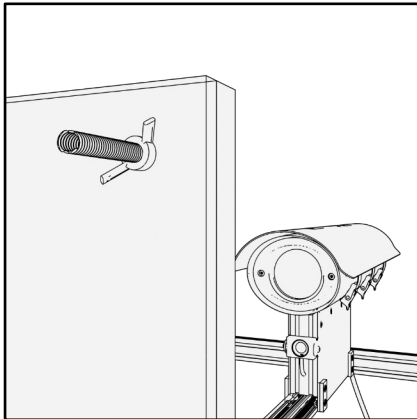

Change canvas

The white foam should be cleaned during the season occasionally with a damp microfiber cloth to remove any dirt.

After one year/at the start of a new season, the foam might be dirty and needs to be turned around or replaced. The foam is secured at the four corners with screws and wing nuts.

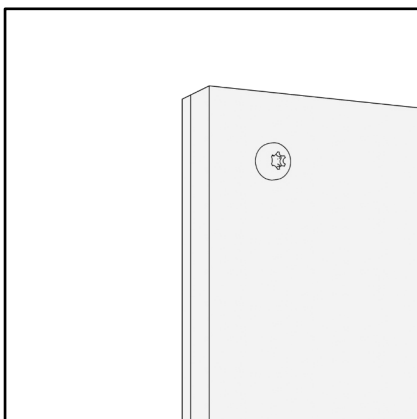

Loosen the wing nuts and remove the screws. Turn the foam so that the side that was previously facing the camera is now directly against the mount. Then reinsert the screws and tighten them by hand with the wing nuts. The foam should be secure but not squashed.

Service

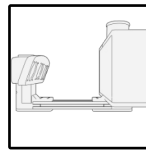
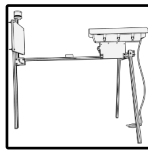

13.3 Replacing the RTC battery

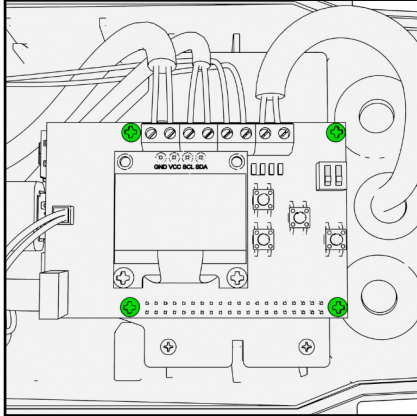

Unscrew the circuit board

As soon as ARNI displays [error 17](#), the real-time clock battery is flat. It must be replaced as soon as possible.

Loosen the 4 screws marked in green. Carefully lift the circuit board upwards. Take care not to damage any cables.

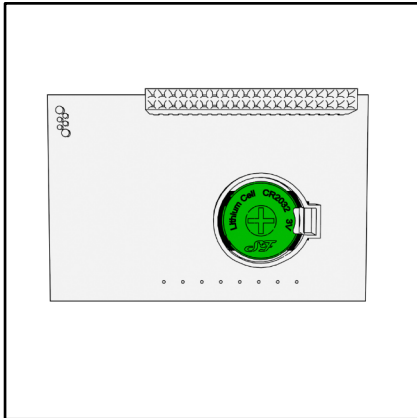

Location of the battery on the underside

The battery (green) is held in place by a clip on the underside of the circuit board. When replacing it, care must be taken not to damage the springs.

The clock will need to be [reset](#) the next time ARNI is started.

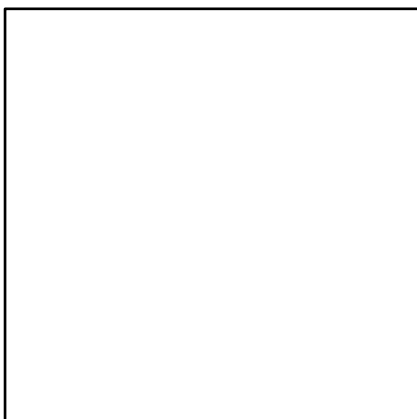
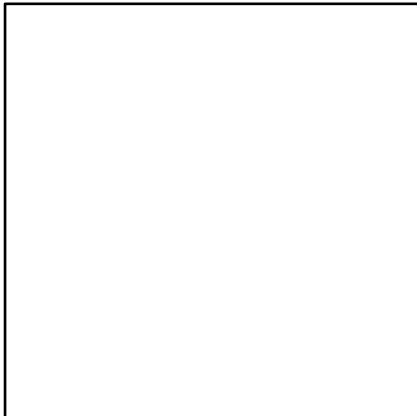

Service

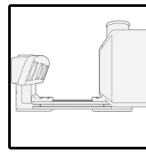
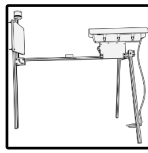

14 Firmware-Update

Updates version 2.3.0 and above differ significantly from the previous procedure. With these updates, the entire micro SD card of the Raspberry Pi, which is installed in the ARNI, must be rewritten. We provide all the necessary files.

Preparation

Please download the following file:

<https://lepmon.de/en/arni-firmware-2/>

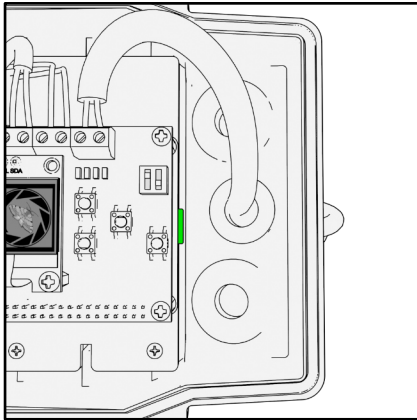

This file must be installed on the Raspberry Pi's micro SD card. The card is inserted in the far right slot of the camera housing. First, switch off the ARNI. Then carefully remove the card (marked in green) from the control unit. We recommend using tweezers.

To install the file onto the SD card, you will need the "Raspberry Pi Imager". If this is not yet installed on your computer, you can download it for free here:

<https://www.raspberrypi.com/software/>

Connect the micro SD card to your computer. You can use the SD card adapter that we included with your delivery. Your computer should recognise this card as 'bootfs' with a size of 512 MB (Windows and Mac). The remaining steps are carried out in the Raspberry Pi Imager.

Service

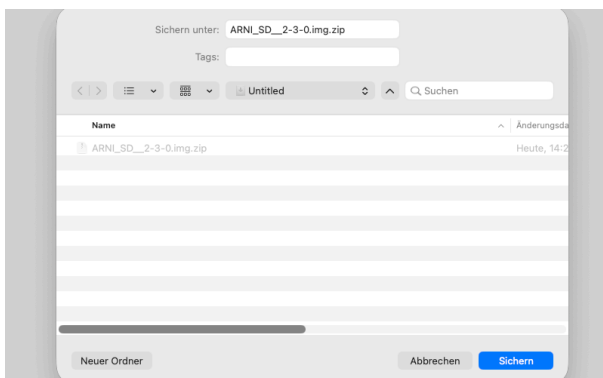
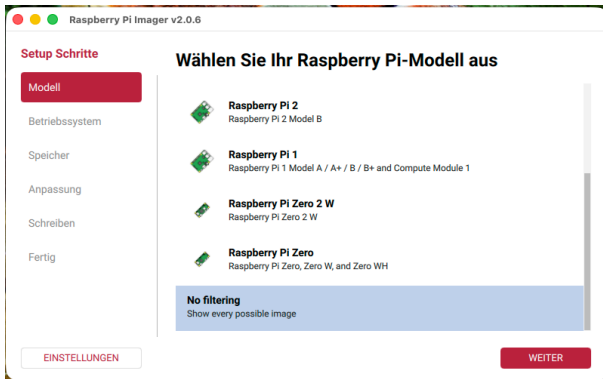
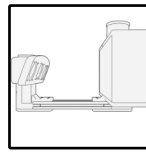
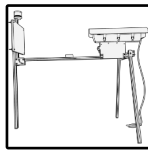

Image Download

The download link takes you directly to the Raspberry Pi image file. Download this file. It is approximately 2 GB in size.



Raspberry Imager

As soon as the Raspberry Pi Imager is opened, it guides you through the installation process. The items in the left-hand menu are taken through one by one.

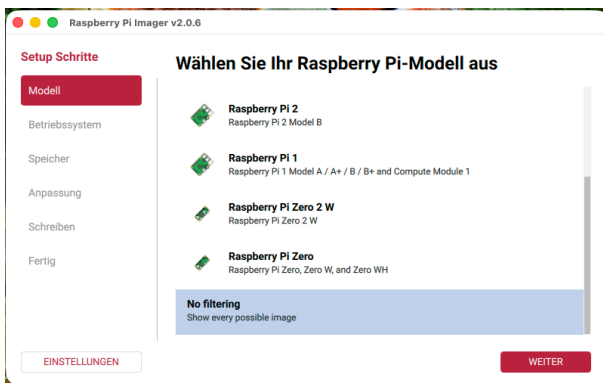

Device

Scroll right to the bottom and select: **No filtering**

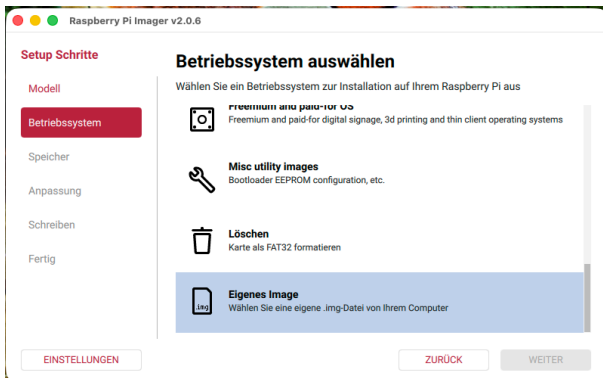

Select operating system

At the very bottom, select 'Custom image'

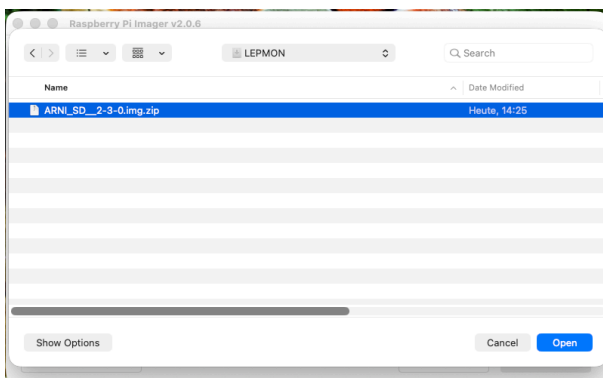

Select image file

A file browser will open. Navigate to the downloaded file and select it.

Service

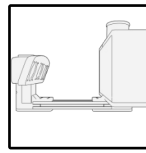
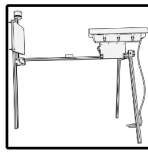

Select image file

The file has now been selected.

Press Continue

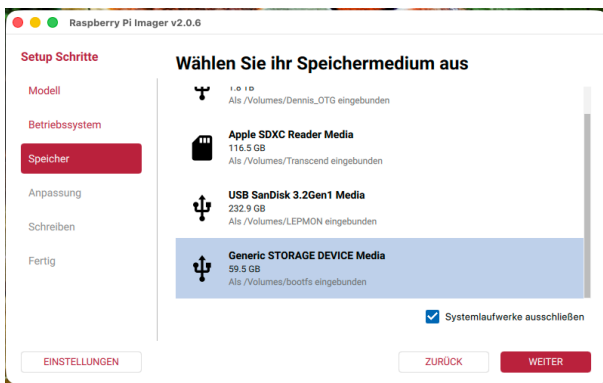

Storage medium

Select the SD card. **Please ensure that no other storage medium is selected, as this will be completely and irrevocably deleted later.**

Start writing. (Delete and write)

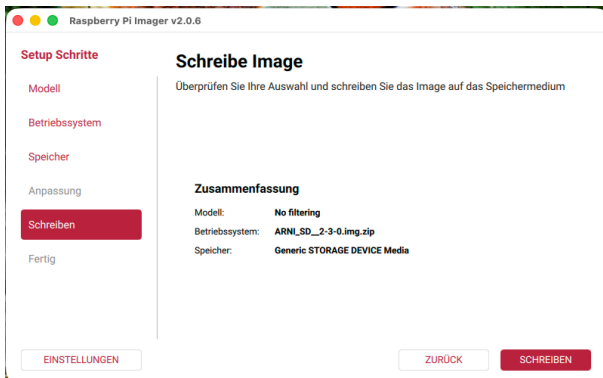

Write image

Once everything is set up correctly, press Write

When the process starts, the imager will ask for access to the SD card (this may look different depending on the computer)

Service

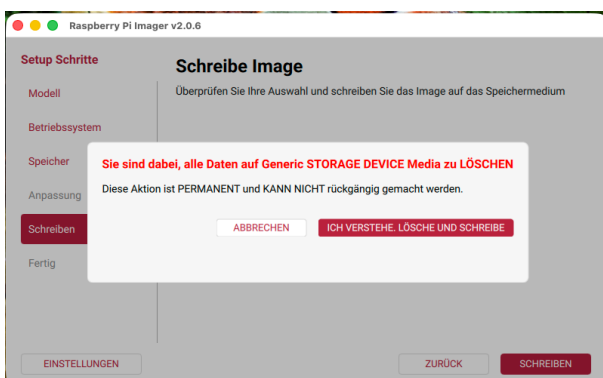

Confirm

The imager will warn you that all data on the selected storage medium will be deleted. If this is the ARNI's SD card, confirm.

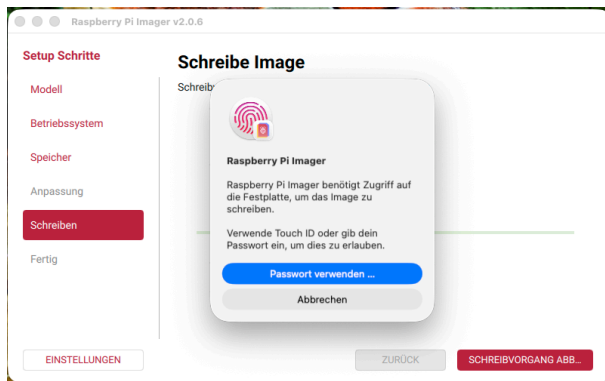
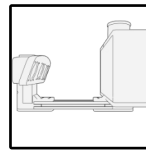
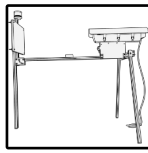

Access

Enable access to the storage medium.

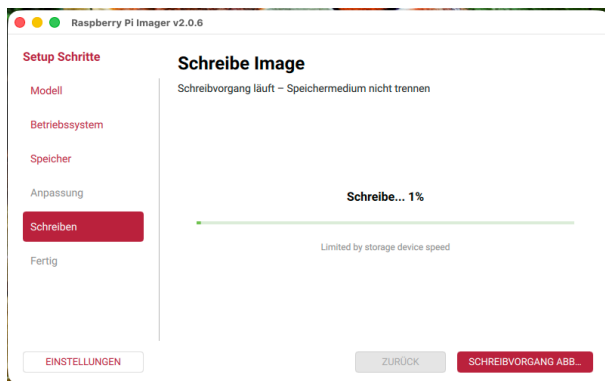

Writing process

The progress bar fills up slowly as data is being written to the SD card. The progress bar may go beyond 100%.

Keep an eye out for any error messages.

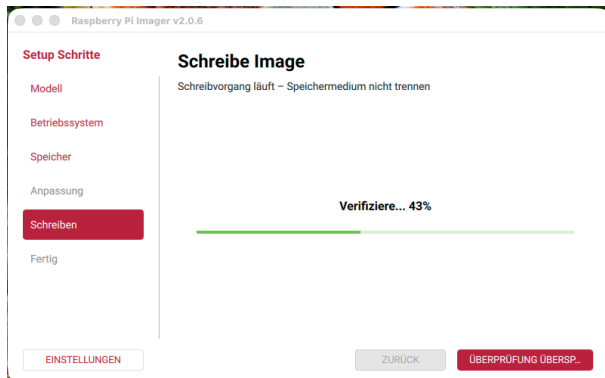

Verify

The card is being checked. It will then be ejected. Please remove the card from the computer.

Service

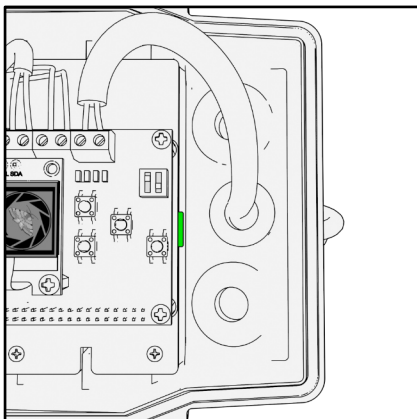

Restart

Reinsert the card into the Raspberry Pi and switch on ARNI

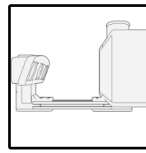
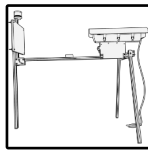

15 errors

ARNI can display various errors. There are two types of errors:

Deficiency:

Malfunctions of individual or multiple components that impair the operation of the ARNI and prevent the completeness of the data. However, operation is still possible. Errors occur, for example, in the communication between the sensors and the control unit.

Critical errors:

Failure of one or more components that makes it impossible for the ARNI to operate (or impairs its operation). Critical errors occur, for example, in communication between the control unit and the camera or the USB stick.

ARNI restarts
in
60 seconds

ARNI itself displays errors at various points in the program and diagnosis and provides instructions to the user on how to rectify the error, e.g., by checking a cable connection. If an error causes the program to terminate, ARNI displays the error code and a brief description.

The program is designed to attempt to correct critical errors by restarting if no interaction is performed by the user.

Errors

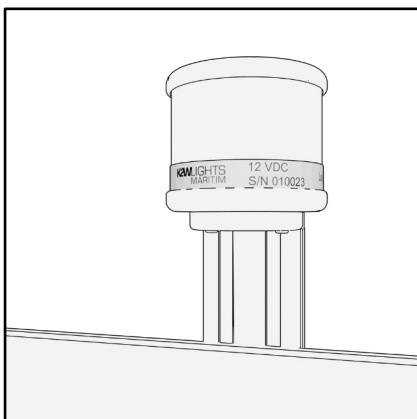

If your ARNI displays one or more errors, please read the following table carefully. Please also contact the LEPMON team, even if you have already been able to resolve the error. Have the serial number (SN xxx label on the UV lamp) of your ARNI and the location and name of the supervisor ready.

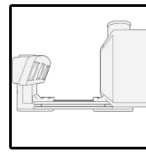
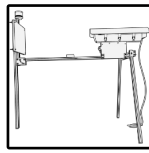

1

Critical error

Error 1
Camera - Check
cable connection

Error in communication between the camera and the Raspberry Pi. ARNI was unable to capture images.

error handling

Turn off ARNI. The camera is connected to the Raspberry Pi using a [USB Y-cable](#). Carefully check that all three plugs are properly connected and turn your ARNI back on. Also check that a USB stick is inserted correctly.

Camera**Critical error**

Camera - Check
cable connection
n/91

Error in communication between the camera and the Raspberry Pi. The Raspberry Pi is attempting to access the camera and displays the number of attempts (n). No image has been captured yet.

error handling

The camera is connected to the Raspberry Pi using a [USB Y-cable](#). Carefully check that all 3 plugs are correctly connected and switch your ARNI back on. Also check that a USB stick is inserted correctly.

2

Critical error

Error 2
Camera busy
not initialized

This error may occur during focusing. ARNI was unable to capture a new image to determine the focus value several times in succession.

error handling

Restart ARNI and call up the focus menu again. Note: ARNI detects this error itself and calls up this menu again automatically.

Errors

3

Critical error

Error 3
USB stick - Check
connection

ARNI was unable to access the (connected) USB stick.

error handling

If the red indicator LED flashes up to 10 times and the error persists: Switch off ARNI and check that the USB stick is inserted correctly and pushed in as far as it will go. Switch ARNI back on again. If the error occurs repeatedly, replace the USB stick.

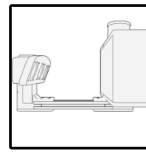
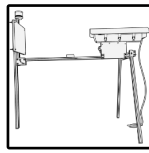

4

deficiency

Error 4
Light sensor - Check
sensor cable

The integrated light sensor does not communicate with the Raspberry. To ensure data collection, a threshold value for ambient light is assumed (90 lux) and ARNI generates data between 15 minutes before dusk and 60 minutes before dawn.

error handling

During the input menu, note the [accesses](#) and check the cable connections on the circuit board.

5

deficiency

Error 5
Outdoor sensor -
Check sensor cable

The integrated environmental sensor does not communicate with the Raspberry. ARNI does not record outside temperature, air pressure, or humidity.

error handling

During the input menu, note the [accesses](#) and check the cable connections on the circuit board.

6

deficiency

Error 6
Inner sensor
board error

The integrated indoor sensor does not communicate with the Raspberry. ARNI does not record indoor temperature.

error handling

Pay attention to [accesses](#) during the input menu. If the error persists, contact the LEPMON team immediately.

Errors

7

deficiency

Error 7
Current sensor
board error

The integrated current sensor does not communicate with the Raspberry. ARNI does not measure power consumption or the status of the spotlight. When operating on solar power, the battery is not monitored.

error handling

Open the menu. If the error persists, contact the LEPMON team immediately.

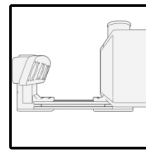
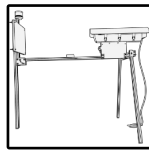

8

deficiency

Error 8
Hardware clock
not found

Error in communication with the external clock. This error may occur if an invalid format was entered when setting the time or if the external clock is not accessible.

error handling

If the error occurs during the input menu, switch ARNI off and on again. In the input menu, check whether a valid time stamp has been entered. If the error occurs repeatedly, contact the LEPMON team immediately and check the button cell battery as instructed.

9

deficiency

Error 9
FRam
board error

Error in communication between Raspberry and Fram module.

error handling

Check if a firmware update is available and contact the LEPMON team.

10

deficiency

Error 10
Logging
Check USB

ARNI was unable to create the [log file](#) or write an entry to it.

error handling

Turn off ARNI and check whether the stick is inserted in the correct orientation and pushed in as far as it will go. Turn ARNI back on. If the error occurs repeatedly, check whether a firmware update is available.

Errors

11

deficiency

Error 11
Checksum not
calculated

ARNI creates a so-called checksum for each file. This is determined after the file has been saved. If the file is not available because it has not been created, error 11 is logged.

error handling

Check the [log file](#) on the USB stick.

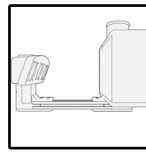
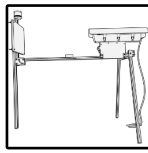

12

deficiency

Error 12
Visible LED
darkened

The illumination LED is dimmed and the screen is not fully illuminated during image capture.

error handling

Check the connection of the power supply or solar system, including the battery. Also check the images from the relevant time and inform the LEPMON team.

13

deficiency

Error 13
Metadata table
Software/ USB error

Current data such as measured values, image name, or timestamp could not be written to the [metadata table](#).

error handling

Turn ARNI off and then on again

14

deficiency

Error 14
Sanity Check
Photo incomplete

The current image has not passed the completeness check and will be re-recorded.

error handling

Turn off ARNI. The camera is connected to the Raspberry Pi using a [USB Y-cable](#). Carefully check that all three plugs are properly connected and turn your ARNI back on. Also check that a USB stick is inserted correctly. Check the [log file](#) on the USB stick.

Errors

15

Critical error

Error 15
Package installation
failed

An error occurred while installing additional Python packages. This may cause parts of the firmware to no longer function or to exhibit unexpected behavior.

Fehlerbehandlung

Inform the LEPMON team immediately and install any available firmware updates right away. Further steps must be taken in consultation with the LEPMON team.

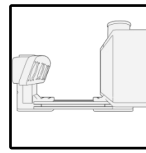
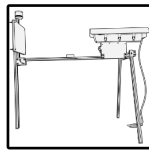

16

deficiency

Error 16
Country/ Region
not determined

The country/region of the entered coordinates could not be determined. The [LEPMON code](#) is not affected by this.

error handling

Check the coordinates you entered manually and very carefully. To do this, return to the GPS menu using the right arrow key before running the diagnostic test.

17

Critical error

Error 17
Button cell battery
Check RTC

The ARNI's external clock is powered by a button cell battery. This battery is flat.

error handling

Replace the watch battery, following the maintainance instructions.

Red LED flashes 3x3

Display error

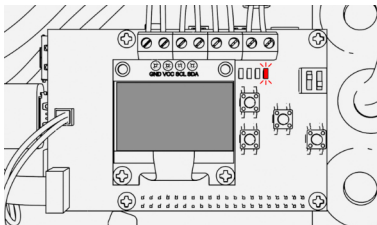

The Raspberry Pi cannot control the OLED display. The input menu cannot be operated, but ARNI still takes pictures

error handling

The display is plugged in. Give the display a wiggle and restart ARNI.

Errors

Please select

Critical error

Please select
SN010023
Pro_Gen_3

ARNI is having an issue with the generation entries on the RAM, or the generation does not match the [serial number](#).

error handling

Use **up/down** to scroll through this menu to the correct serial number, then press **Enter** or **right** to confirm.

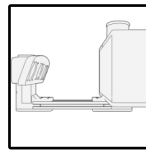
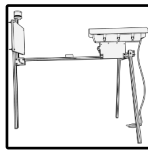

16 Output

16.1 Sample log file

Hinweis: ARNI schreibt die Log-Datei immer auf Deutsch, unabhängig von der [eingestellten Sprache](#)

```

20:41:00; Logfile erstellt: /media/Ento/INTENSO/Lepmon#SN010023_TH_J_2026-05-14_T_2041/
Lepmon#SN010023_TH_J_2026-05-14_T_2041.log
20:41:00; =====
20:41:00; Run Informationen
20:41:00; -----
20:41:00; Letzter Durchlauf | ordnungsgemäß beendet. Fahre mit dem neuem Ordner fort:
20:41:00; Alter Ordner:      | /media/Ento/stick/Lepmon#SN010023_TH_J_2026-05-13_T_2039/
20:41:00; Neuer Ordner:      | /media/Ento/stick/Lepmon#SN010023_TH_J_2026-05-14_T_2041/
20:41:00; =====
20:41:00; Gerätedaten
20:41:00; -----
20:41:00; ARNI SN Nummer:    | SN010023
20:41:00; ARNI Generation:   | Pro_Gen_3
20:41:01; verbaute Kamera:  | AV__Alvium__1800_U-2050
20:41:01; verbauter Sensor: | imx183
20:41:01; Auflösung (LxB): | 5496 x 3672
20:41:01; Red Balance    | 2.169922
20:41:01; Blue Balance   | 2.049805
20:41:02; ARNI run:         | SN010023__0016
20:41:02; Firmware:         | 2.3.2 vom 2026-05-21
20:41:02; =====
20:41:02; Experiment Zeiten
20:41:02; -----
20:41:17; Beginn Experiment: | 2026-05-14
20:41:17; Attiny on:           | 20:23:04
20:41:17; Sonnenuntergang:  | 20:38:04
20:41:17; Start Aufnahme:  | 20:48:04
20:41:17; Verzögerung Start: | 10 Minuten
20:41:17; -----
20:41:17; Ende Experiment:    | 2026-05-15
20:41:17; Ende Aufnahme:    | 04:27:51
20:41:17; Attiny off:      | 04:32:51
20:41:17; Sonnenaufgang:   | 05:27:51
20:41:17; =====
20:41:17; Vergleiche Experiment Zeiten
20:41:17; -----
20:41:17; gespeicherter Anfang | 2026-05-14 20:23:04
20:41:17; gespeichertes Ende | 2026-05-14 04:32:51
20:41:17; Differenz Startzeiten | 0:00:00
20:41:17; eine positive Differenz oder 0:00 ist erwartet - der im letzten Run errechnete Startzeitpunkt
liegt vor dem tatsächlichen. Kein Datenverlust ist erwartet
20:41:19; =====
20:41:19; Lese RTC Status:
20:41:19; -----
20:41:19; Alarm 1 Status      | False
20:41:19; Alarm 2 Status      | False
20:41:19; -----
20:41:19; Setze Alarime zurück...
20:41:19; Alarime zurückgesetzt.

Bei Fehler 17:
20:41:19; Fehler beim Zurücksetzen der Alarime: Fehlerdetails
20:41:19; RTC hat seit dem letzten Schreiben Stromverlust erfahren: True
20:41:19; WARNUNG: Knopfzellen Batterie der RTC muss kontrolliert werden. Die Uhrzeit wird beim
nächsten Start von ARNI, nachdem die Stromversorgung unterbrochen war, auf 2000 zurückgesetzt.
20:41:22; Fehler 17: Prüfe Knopfzellen Batterie der RTC: check RTC battery

20:41:24; #####
20:41:24; #####
20:41:24; beende start_up
20:41:24; #####
20:41:24; #####

```

Output

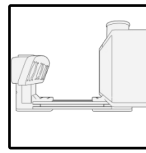
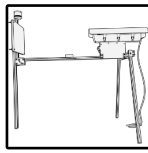

Bei **Pakete** Installation:

```
20:41:37; Starte Installation von Python Paketen...
20:41:37; erwarte installation für pycountry, h3, opencv-python, numpy
20:41:37; pycountry ist bereits installiert und wird deinstalliert
20:41:41; pycountry wurde deinstalliert
20:41:48; opencv-python ist bereits installiert und wird deinstalliert
20:41:50; opencv-python wurde deinstalliert
20:41:50; numpy ist bereits installiert und wird deinstalliert
20:41:53; numpy wurde deinstalliert
20:41:53; Installiere fehlende Pakete: pycountry, opencv-python, numpy
20:41:53; Versuche Installation von opencv_python-4.8.1.78-cp37-abi3-manylinux_2_17_aarch64.
manylinux2014_aarch64.whl ...
20:42:02; opencv_python-4.8.1.78-cp37-abi3-manylinux_2_17_aarch64.manylinux2014_aarch64.whl
installiert
20:42:11; Versuche Installation von numpy-1.26.4-cp311-cp311-manylinux_2_17_aarch64.
manylinux2014_aarch64.whl ...
20:42:33; numpy-1.26.4-cp311-cp311-manylinux_2_17_aarch64.manylinux2014_aarch64.whl
installiert
20:42:33; Versuche Installation von pycountry-24.6.1-py3-none-any.whl ...
20:42:43; pycountry-24.6.1-py3-none-any.whl installiert
20:42:43; Alle Pakete erfolgreich installiert!
20:42:45; Installation von Python Paketen beendet
20:42:45; -----
```

Bei aufgerufenem **Eingabe Menü**:

```
20:42:50; Lokales User Interface von ARNI wurde geöffnet. Es wurde zum 0026 mal geöffnet
20:42:51; -----
```

„kleines Update“ via USB

```
20:42:53; Menü zum Updaten geöffnet
20:42:58; Update-Stick ist gültig und Update erlaubt
20:43:03; altes Programm im Ordner LepmonOS_2_3_2-2026-04-02 hinterlegt
20:43:03; alter Programmordner erfolgreich gelöscht
20:43:12; neue LepmonOS Version erfolgreich geladen
20:43:12; logging path und Geräteinformationen im neuer Config auf alte Werte gesetzt
20:43:18; Update-Ordner LepmonOS_update vom USB Stick gelöscht
20:43:19; Update erfolgreich abgeschlossen. Neue Firmwareversion: 2.3.3
20:43:19; leite Neustart ein, um Update abzuschließen
20:43:25; -----
20:43:29; sofortiger Reboot in 5 Sekunden
20:43:34; #####
20:43:34; ### SELBSTINDUZIERTER SHUTDOWN ###
20:43:34; #####
```

Fehler im Update Prozess

```
20:42:58; version.txt auf dem Stick nicht gefunden
20:42:58; Konnte aktuelle Version nicht lesen
20:42:59; Fehler bei safe_rmtree_files: Fehlerdetails
20:42:59; Fehler bei safe_rmtree_dirs: Fehlerdetails
20:42:59; Fehler beim Löschen des alten LepmonOS: Fehlerdetails
20:42:59; Fehler beim Löschen des Update-Ordners: Fehlerdetails
```

Bei nicht gefundenem Update Paket auf dem USB Stick:

```
20:42:57; Update nicht erlaubt oder kein gültiger Update-Stick gefunden.
20:42:57; Firmwareversion bereits aktuell
20:42:57; kein Update gefunden
20:42:57; fahre fort
20:43:02; -----
20:43:02; Fokussierhilfe geöffnet
20:43:03; Fokussierhilfe im Web Interface geöffnet
20:43:37; Fokus gefunden mit Schärfewert: 61.0
20:43:37; Fokussieren beendet
20:43:37; -----
```

Output

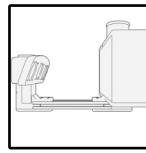
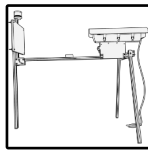

20:43:37; [Sprachmenü](#) geöffnet
 20:43:39; gespeicherte Sprache: de
 20:43:39; Sprachmenü geschossen
 20:43:52; -----
 20:43:52; [Stromversorgung](#) auf Netz gesetzt
 20:43:56; -----
 20:43:56; Menü zum [Löschen des USB Sticks](#) geöffnet
 20:43:58; Ordner gelöscht: /media/Ento/INTENSO/Lepmon#SN010023_TH_J_2026-05-14_T_2120
 20:44:00; Datei gelöscht: /media/Ento/INTENSO/Lepmon#SN010023_TH_J_2026-05-14_T_2120.
 Key
 20:44:00; Menü zum Löschen des USB Sticks geschlossen
 20:44:04; -----
 20:44:04; [Scheibenheizung](#) wird aktiviert
 20:44:04; -----
 20:44:04; Menü zum aktualisieren der Uhrzeit geöffnet
 20:44:14; Hardware [Uhrzeit](#) gesetzt auf: 2026-05-14 20:44:14
 20:44:14; Menü zum aktualisieren der Uhrzeit geschlossen
 20:44:14; -----
 20:44:14; Menü zum aktualisieren der [Koordinaten](#) geöffnet
 20:44:18; alte Koordinaten: Breite 50.9241073, Länge 11.5837985
 20:44:31; Länge unverändert
 20:44:31; neue Koordinaten: Breite 50.9241072, Länge 11.5837985
 20:44:31; neue Koordinaten wurden gespeichert
 20:44:34; Eingegebene Koordinaten befinden sich in Land: Germany, Region: Thüringen
 20:44:39; Nutzender hat bestätigt, dass die eingegebenen Koordinaten in der Zielregion liegen
 20:44:39; Menü zum aktualisieren der Koordinaten geschlossen
 20:44:44; -----
 20:44:44; Menü zum Ändern der Provinz und Kreiskürzel geöffnet. Erwarte neuen [LEPMON-Code](#)
 20:45:10; Land unverändert: Germany
 20:45:11; Provinz unverändert: Thüringen
 20:45:11; Kreis unverändert: J
 20:45:11; Menü zum Ändern der Provinz und Kreiskürzel beendet. Es wurden keine Änderungen
 eingegeben. Fahre fort
 20:44:44; -----
 20:45:11; [LEPMON-Code](#) in Konfigurationsdatei geschrieben: TH, J
 20:45:11; Eingaben beendet
 20:45:14; Starte Systemcheck

Bei einem Fehler in der Verbindung zu den Sensoren:

20:45:17; [Fehler 4](#): Fehler in der Verbindung zum Lichtsensor. Wert des Umgebungslichtes auf Schwellenwert gesetzt: 90: No I2C device at address: 0x23

20:45:21; [Fehler 5](#): Fehler in der Verbindung zum Umweltsensor: cannot access local variable 'bme280' where it is not associated with a value

20:45:23; =====

20:45:23; Sensoren

20:45:23; -----

Sensor	Status	Wert	Einheit
Light_Sensor	Fehler	---	Lux
Inner_Sensor	OK	36.38	°C
Power_Sensor	OK	11.91	V
Environment_Sensor	Fehler	---	°C

20:45:23; -----

Sensor	Status	Wert	Einheit
Light_Sensor	Fehler	---	Lux
Inner_Sensor	OK	36.38	°C
Power_Sensor	OK	11.91	V
Environment_Sensor	Fehler	---	°C

20:45:25; Inner_Sensor | OK | 36.38 | °C

20:45:27; Power_Sensor | OK | 11.91 | V

20:45:28; Environment_Sensor | Fehler | --- | °C

20:45:23; =====

20:45:32; Alle Sensoren nach erneutem Auslesen OK

20:45:23; =====

20:45:23; Sensoren

20:45:23; -----

Sensor	Status	Wert	Einheit
Light_Sensor	OK	8.33	Lux
Inner_Sensor	OK	35.88	°C
Power_Sensor	OK	11.91	V
Environment_Sensor	OK	21.82	°C

20:45:23; -----

Sensor	Status	Wert	Einheit
Light_Sensor	OK	8.33	Lux
Inner_Sensor	OK	35.88	°C
Power_Sensor	OK	11.91	V
Environment_Sensor	OK	21.82	°C

20:45:25; Inner_Sensor | OK | 35.88 | °C

20:45:27; Power_Sensor | OK | 11.91 | V

20:45:28; Environment_Sensor | OK | 21.82 | °C

20:45:28; =====

Output

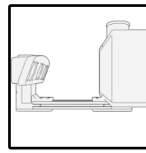
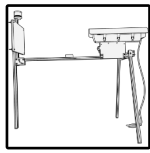

```

20:45:43; starte Kameratest...
20:45:43; Teste Allied Vision Kamera
20:45:43; Kamera wird eingeschaltet und initialisiert..
20:45:43; Dateipfad für Testbild: /media/Ento/INTENSO/Testbild.jpg
20:45:43; Versuche Frame von Kamera abzurufen...
20:45:43; Frame erfolgreich von Kamera abgerufen
20:45:43; Testbild erfolgreich gespeichert
20:45:43; Test-Bild vom Speicher gelöscht: /media/Ento/INTENSO/Testbild.jpg
20:45:43; Kamera Zugriff erfolgreich
20:45:43; Kamera Test erfolgreich beendet

```

Bei nicht oder falsch angeschlossener Kamera:

```

20:46:56; Kamera Test fehlgeschlagen, Kamera nicht verfügbar
20:45:46; =====
20:46:56; USB Speicher
20:46:56; -----
20:46:56; gesamt          | 468.72 GB |
20:46:56; belegt          | 0.01 GB  | 0 %
20:46:56; frei            | 468.71 GB | 100 %
20:45:46; =====
20:46:56; USB Speicher OK

```

Bei vollem USB Stick:

```

20:45:46; USB Speicher fast voll bitte leeren
20:45:46; =====
20:45:46; Sonnen Zeiten
20:45:50; -----
20:45:50; Sonnenuntergang | 20:53:04
20:45:50; Sonnenaufgang   | 05:27:51
20:45:50; -----
20:45:46; #####
20:45:46; #####
20:45:46; Beende Systemcheck
20:45:46; #####
20:45:46; #####
20:45:46; =====
20:45:46; verwendete Einstellungen
20:45:50; -----
20:45:50; Breite          | 50.9241072
20:45:50; Länge           | 11.5837985
20:45:50; -----
20:45:50; Stromversorgung | Netz
20:45:50; =====
20:45:50; warte auf Beginn | 0:02:10 oder nein, starte Schleife
20:45:50; =====
20:48:11; Schalte USB Ports des Raspberry aus
20:48:11; USB Ports des Raspberry eingeschaltet
20:48:16; #####
20:48:16; #####

```

Beginn Aufnahmeschleife:

```

20:48:16; =====
20:48:16; Daten und Bildaufnahme:
20:48:16; -----
20:48:16; Gamma Korrektur | 0.4
20:48:16; -----
20:48:16; USB Speicher
20:48:16; -----
20:48:16; gesamt          | 468.72 GB |
20:48:16; belegt          | 0.01 GB  | 0 %
20:48:16; frei            | 468.71 GB | 100 %
20:48:16; -----

```

Output

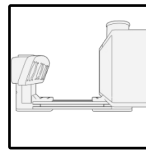
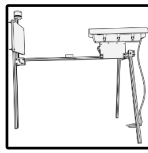

Bei fehlerhaftem USB Stick:

20:48:16; Fehler beim Überprüfen des USB-Speicherplatzes: Fehlerdetails
 20:48:16; erwartete Bilder | 467
 20:48:16; =====
 20:48:16; #####
 20:48:16; #####
 20:48:24; Scheibenheizung zu Beginn der Aufnahme Schleife eingeschaltet
 20:48:24; LepiLED eingeschaltet
 20:48:24; -----
 20:48:40; Exposure erhöht von 135 auf 140
 20:48:52; Bild gespeichert: /media/Ento/INTENSO/Lepmon#SN010023_TH_J_2026-05-14_T_2041/
 Lepmon#SN010023_TH_J_2026-05-14_T_2048.jpg
 20:49:01; Warten bis zur nächsten Aufnahme: 120 Sekunden. Aktuelle Kamerafehlerserie: 0
 20:50:20; Gain verringert von 5 auf 4.5
 20:50:28; Bild gespeichert: /media/Ento/INTENSO/Lepmon#SN010023_TH_J_2026-05-14_T_2041/
 Lepmon#SN010023_TH_J_2026-05-14_T_2050.jpg
 20:52:30; Warten bis zur nächsten Aufnahme: 90.0 Sekunden. Aktuelle Kamerafehlerserie: 0
 20:54:16; Sowohl Exposure als auch Gain haben das Maximum erreicht. Keine weitere Erhöhung
 möglich.
 20:54:24; Bild gespeichert: /media/Ento/INTENSO/Lepmon#SN010023_TH_J_2026-05-14_T_2041/
 Lepmon#SN010023_TH_J_2026-05-54_T_2045.jpg
 20:54:33; Warten bis zur nächsten Aufnahme: 87.0 Sekunden. Aktuelle Kamerafehlerserie: 0
 21:00:38; Bilder der AV__Alvium_1800_U-2050 sind scharf: Schwellenwert: 100, gemessene
 Fokusvarianz: 100,21

Weißabgleich

21:00:48; Trigger für Weißabgleich aktiviert und Zeit für WB Anpassung erreicht. Starte
 Weißabgleichsanpassung...
 21:01:18; Starte Weißabgleichsberechnung für Bild: /media/Ento/INTENSO/Lepmon#SN010023_
 TH_J_2026-05-14_T_2041/Lepmon#SN010023_TH_J_2026-05-54_T_2045.jpg
 21:01:18; Maske erstellt mit Threshold: 205.0
 21:01:18; Berechne RGB-Mittelwerte für 2237184 Hintergrundpixel...
 21:01:18; Berechnete WB-Verhältnisse -> Rot: 0.919, Blau: 1.083
 21:01:18; #####
 21:01:18; #####
 21:01:18; verwendete Maske:
 21:01:18; Matrix_BW_Beginn
 21:01:18; Hinweis: diese Maske ist durch 0/1 codiert



21:01:20; Matrix_BW_Ende
 21:01:20; #####
 21:01:20; #####

Output

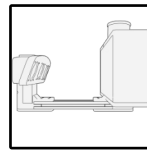
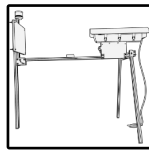

21:01:20; Übernahme Weißabgleich:
 21:01:20; Red Balance old | 2.169922
 21:01:20; Blue Balance old | 2.049805
 21:01:20; Red Balance new | 1.995035
 21:01:20; Blue Balance new | 2.219208
 21:01:20; Weißabgleichsanpassung abgeschlossen und Trigger zurückgesetzt.
 21:01:22; Warten bis zur nächsten Aufnahme: 62.0 Sekunden. Aktuelle Kamerafehlerserie: 0

Bei fehlerhaft gespeicherten Bildern

21:00:38; unvollständiges Foto media/Ento/INTENSO/Lepmon#SN010023_TH_J_2026-05-14_T_2041/Lepmon#SN010023_TH_J_2026-05-14_T_2045.jpg erkannt. ARNI nimmt neu auf.
 Fehlerdetails: Path does not exist"
 21:01:00; Kein Frame zum Speichern vorhanden
 21:01:03; Fehler bei der Bildprüfung: Fehlerdetails
 21:01:05; Foto hat Sanity Check nach 4 Versuchen endgültig nicht bestanden.

Bei Kamera Fehler 1 und 3 - Mögliche Details:

21:00:38; Fehler beim Laden der Kameraeinstellungen: File not found
 21:00:38; Fehler beim Setzen der Belichtungszeit: out of range
 21:00:38; Fehler beim Setzen des Gains: out of range
 21:00:38; Fehler beim Setzen von Gamma: out of range
 21:00:38; unbekanntes Pixelformat: Camera does not support RGB8
 21:00:38; Fehler bei der Frame Aufnahme: tuple index out of range
 21:00:38; Fehler beim Abrufen des Frames: Camera does not support RGB8
 21:00:38; Fehler beim Kopieren der Kameraeinstellungen: File not found error
 21:00:38; Fehler beim Speichern des Bildes: Path not found

Bei unscharfen Bildern von allen Pro Generationen:

21:00:38; WARNUNG: Bilder der AV__Alvium_1800_U-2050 sind verschwommen: Schwellenwert: 100, gemessene Fokusvarianz: 89,39

Bei unscharfen Bildern CS_Gen_1

21:00:38; WARNUNG: Bilder der RPI_Module_3 sind verschwommen: Schwellenwert: 100, gemessene Fokusvarianz: 56,32
 21:00:38; Unschärfe Bilder erkannt. Starte Fokussierung ...
 21:00:55; Fokus RPI Module 3 geändert von 5.3 auf 5.2

21:00:59; Schalte USB Ports des Raspberry aus
 21:01:08; USB Ports des Raspberry eingeschaltet

...

05:26:25; Bild gespeichert: /media/Ento/INTENSO/Lepmon#SN010023_TH_J_2026-05-14_T_2041/Lepmon#SN010023_TH_J_2026-05-15_T_0526.jpg
 05:26:25; Warten bis zur nächsten Aufnahme: 30.0 Sekunden
 05:26:25; #####
 05:26:25; #####
 05:26:25; in dieser Nacht wurden 1.2 GB an Daten generiert
 05:26:25; erwartete Bilder: 467, aufgenommene Bilder: 467
 05:26:25; dimme LepiLED herunter
 05:26:25; #####
 05:26:25; #####
 05:26:25; Beende Aufnahme Schleife. Leite zum Ausschalten über
 05:26:25; Leite zum Ausschalten über...
 05:26:25; #####
 05:26:25; #####

05:25:55; Fehlercode vor Shutdown: 3
 05:26:01; nächstes Anschalten: 2026-05-15 20:35:12
 05:26:01; nächstes Ausschalten berechnet, Zeitstempel zum schreiben: 2026-05-16 05:25:46
 05:26:05; Alarm für nächstes Anschalten gesetzt auf: 2026-05-15 20:35:12
 05:26:05; Alarm für nächstes Ausschalten gesetzt auf: 2026-05-16 05:25:46
 05:26:20; Reboot im Netzmodus in 5 Sekunden
 05:26:25; #####
 05:26:25; ### SELBSTINDUZIERTER SHUTDOWN ###
 05:26:25; #####

Output

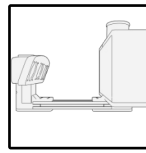
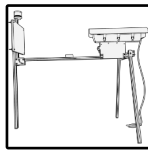

Bei Zeitumstellung im Frühjahr und Herbst während der Nacht:

08:06:13; Stelle UhrZeit um
08:06:15; neue Zeit: 07:06:135 wird um -1 Stunde(n) geändert

Bei Zeitumstellung + Zwischenzeitlichem Stromausfall

08:08:17; Zeitumstellung bereits an diesem Tag durchgeführt

Bei Neustart während der Nacht:

21:14:25; #####
21:14:25; ### Letzter Durchlauf nicht ordnungsgemäß beendet. Fahre mit altem Ordner fort #####
21:14:25; #####
20:42:51; -----
20:41:20; ARNI nicht mit lokalem User Interface parametrisiert
00:45:46; =====
00:45:46; verwendete Einstellungen
00:45:46; -----
00:45:46; Breite | 50.9241072
00:45:46; Länge | 11.5837985
00:45:46; -----
00:45:46; Stromversorgung | Netz
00:45:46; =====
00:45:46; warte auf Beginn | 0:02:10 **oder** nein, starte Schleife
00:45:46; =====
00:45:46; Aktuelle Zeit liegt nach geplantem Nachtbeginn. Starte Schleife

Bei Polartag und Nacht:

13:32:17; Hinweis: Sonne geht heute nicht unter (Polartag).
13:32:17; Setze Sonnenaufgang auf 23:45:00 und Sonnenuntergang auf 00:15:00 für die Berechnung der Experimentzeiten.
13:32:17; Hinweis: Mond geht heute nicht unter (Mondpolartag)
13:32:17; Hinweis: Sonne geht heute nicht auf (Polarnacht).
13:32:17; Setze Sonnenaufgang auf 00:15:00 und Sonnenuntergang auf 23:45:00 für die Berechnung der Experimentzeiten.
13:32:17; Hinweis: Mond geht heute nicht auf (Mondpolarnacht).
13:32:17; Fehler bei der Berechnung der Mondphase oder Kulminationshöhe: Fehlerdetails

Bei Fehlern im Hauptprogramm:

23:15:41; Fehler im HMI: Fehlerdetails
23:15:41; Fehler im Capturing: Fehlerdetails
23:15:41; Fehler im Shutdown: Fehlerdetails

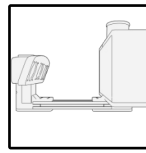
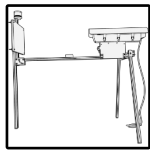

16.3 images



Example from Jena, Thuringia, Germany on July 3, 2025, at 3:34 a.m.







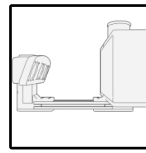
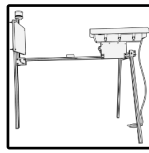





Output

Moth sample from 2025



17 Available LEPMON-Codes

 Albania	69
 Austria	69
 Belgium	70
 Croatia	70
 Czech Republic.....	71
 Denmark	71
 Ecuador	71
 Madagascar	71
 Netherlands	71
 Germany	72
 Italy	78

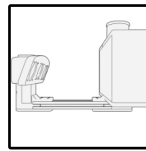
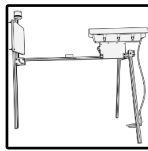

Albania

Berat

BR
KV
SK

Dibër

DI
BZ
MT

Durrës

DR
KR

Elbasan

EL
GR
LB
PE

Fier

FR
LU
MK

Gjirokastrë

GJ
PR
TP

Korçë

KO
DV
ER
PG

Kukës

KU
HS
BC

Lezhë

LE
LA
MR

Shkodër

SH

PU

MA

Tiranë

TR
KJ

Vlorë

VL
DL
SR

Austria

Burgenland

B
GD
HN
JU
OW
WE

Kärnten

K
DO
FR
KL
SP
SV

Niederösterreich

N
GM
GF
HO
KR
LA
ME
MD
MI
NE
PO
SK
SW
TU
WN

Oberösterreich

OO
EF
FR
GR
KI
LL
PE
RO
SD
UR

Salzburg

S
JO
LI
SL

Steiermark

ST
DL
FB
GU
HF
JO
LB
MU
RA
VO

Tirol

T
KU
LA
RE

Vorarlberg

V
DO
FR
HO
MO

Wien

W

**LEPMON
Code**

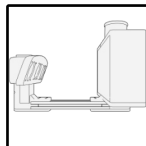
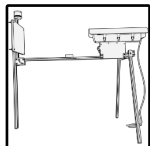

Belgium

Antwerpen

VAN

Brussels-Capital

BRU

Limburg

VLI

Oost-Vlaanderen

VOV

Vlaams-Brabant

VBR

West-Vlaanderen

VWV

Hainaut

WHT

Liège

WLG

Luxembourg

WLX

Namur

WNA

Brabant Wallon

WBR

Croatia

Zagrebačka

ZG

DU

IV

KR

SB

VT

VZ

Krapinsko-zagorska

KZ

KZ

Sisačko-moslavačka

SM

KT

SI

Karlovačka

KA

SL

Varaždinska

VZ

Koprivničko-križevačka

KK

KZ

Bjelovarsko-bilogorska

BB

DA

GR

KZ

Primorsko-goranska

PG

CR

DE

DL

GS

KR

PU

Ličko-senjska

LS

OG

SM

Virovitičko-podravska

VP

SL

Požeško-slavonska

PS

SL

Brodsko-posavska

BP

NG

Zadarska

ZD

PA

Osječko-baranjska

OB

DJ

NA

VS

Šibensko-kninska

SK

DR

KN

Vukovarsko-srijemska

VS

VU

ZU

Splitsko-dalmatinska

SD

IM

MA

OM

SG

SU

VK

Istarska

IS

LB

PA

RO

UM

Dubrovačko-neretvanska

DN

PL

ST

Međimurska

ME

Grad Zagreb

GZ

LEPMON
Code

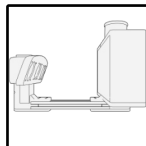

Czech Republic

Hlavní město Praha

PHA

Středočeský kraj

STC

Jihočeský kraj

JHC

Plzeňský kraj

PLK

Karlovarský kraj

KAR

Ústecký kraj

UST

Liberecký kraj

LIB

Královéhradecký kraj

HRA

Pardubický kraj

PAR

Vysočina

VYS

Jihomoravský kraj

JHM

Olomoucký kraj

OLM

Zlínský kraj

ZLN

Moravskoslezský kraj

MSK

Denmark

Hovedstaden

HS

K

T

V

Midtjylland

ML

R

V

Nordjylland

NL

B

Sjælland

SL

L

N

Syddanmark

SM

F

M

Ecuador

Azuay

A

Bolívar

B

Cañar

U

Carchi

C

Chimborazo

H

Cotopaxi

X

El Oro

O

Esmeraldas

E

Galápagos

W

Guayas

G

Imbabura

I

Loja

L

Los Ríos

R

Manabí

M

Morona Santiago

S

Napo

N

Orellana

Q

Pastaza

Y

Pichincha

P

Santa Elena

SE

Santo Domingo de los Tsáchilas

J

Sucumbíos

K

Tungurahua

T

Zamora Chinchipe

Z

Madagascar

Morondava

MD

Tulear

MD

Netherlands

Drenthe

DR

Flevoland

FL

Friesland

FR

Gelderland

GE

LEPMON
Code

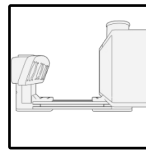
Groningen

GR

Limburg

LI

Noord-Brabant

NB

Noord-Holland

NH

Overijssel

OV

Utrecht

UT

Zeeland

ZE

Zuid-Holland

ZH

HOR

KA

KEL

KN

KUN

LB

LEO

LO

LR

MA

MGH

MOS

MUL

NEU

NT

OG

OHR

PF

RA

RT

RV

RW

S

SAK

SHA

SIG

SLG

STO

TBB

TT

TU

TUT

UB

UL

VAI

VS

WG

WN

WOL

WT

Bayern

BY

AB

AIB

AIC

ALZ

AM

AN

AO

AS

BA

BGD

BGL

BOG

BRK

BT

BUL

CHA

CO

DAH

DEG

DGF

DKB

DLG

DON

EBE

EBN

EBS

ED

EG

EI

ER

ERH

ESB

FDB

FEU

FFB

FO

FRG

FS

FU

 **Germany**Baden-Württemberg

BW

BAD

BB

BC

BCH

BH

BK

BL

BUS

CR

CW

EM

ES

FDS

FN

FR

GD

GP

HCH

HD

HDH

HN

LEPMON
Code

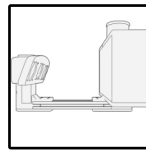
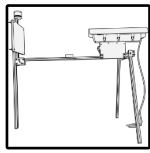

FUS	MM	SEF
GAP	MN	SEL
GEO	MOD	SMU
GRA	MSP	SOB
GRI	MU	SOG
GUN	MUB	SR
GZ	N	STA
HAB	NAB	STE
HAS	NAI	SUL
HEB	ND	SW
HIP	NEA	TIR
HO	NEC	TOL
HOH	NEN	TS
HOS	NES	UFF
ILL	NEW	VIB
IN	NM	VIT
KC	NO	VOH
KE	NU	WEN
KEH	OA	WER
KEM	OAL	WM
KF	OBB	WOR
KG	OCH	WOS
KON	OVI	WS
KOZ	PA	WU
KRU	PAF	WUG
KT	PAN	WUM
KU	PAR	WUN
LA	PEG	<u>Berlin</u>
LAN	R	BE
LAU	REG	<u>Brandenburg</u>
LF	REH	BB
LI	REI	BAR
LIF	RH	BER
LL	RID	BRB
M	RO	BSK
MAI	ROD	CA
MAK	ROL	CB
MAL	ROT	EE
MB	SAD	EH
MET	SAN	EW
MIL	SC	FF

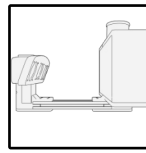
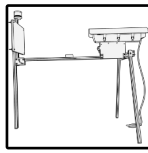

FI	DA	<u>Mecklenburg-</u>
FOR	DI	<u>Vorpommern</u>
FRW	DIL	MV
FW	ERB	AT
GUB	ESW	BUZ
HVL	F	DBR
KW	FB	DM
KY	FD	GDB
LC	FKB	GMN
LDS	FZ	GU
LIB	GG	GVM
LN	GI	GW
LOS	GN	HGN
MOL	HEF	HGW
NAU	HG	HRO
NP	HOG	HST
OHV	HP	HWI
OPR	HR	LBZ
OSL	HU	LRO
P	KB	LUP
PM	KS	LWL
PR	LDK	MC
PZ	LM	MSE
RN	MEG	MST
SDT	MKK	MUR
SEE	MR	NB
SFB	MTK	NVP
SPB	OF	NWM
SPN	ROF	NZ
SRB	RUD	OVP
TF	SLU	PCH
TP	SWA	PW
UM	USI	RDG
WK	VB	RM
<u>Bremen</u>	WA	ROS
HB	WEL	RUG
<u>Hamburg</u>	WI	SBG
HH	WIZ	SN
<u>Hessen</u>	WOH	STB
HE	WZ	TET
BUD		UEM

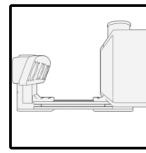
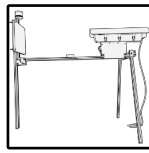

UER	NOH	DIN
VG	NOM	DN
VR	NOR	DO
WIS	OHA	DU
WLG	OHZ	E
WRN	OL	EN
<u>Niedersachsen</u>	OS	ERK
NI	PE	EU
AUR	RI	GE
BRA	ROW	GEL
BRL	SHG	GK
BRV	STD	GL
BS	SY	GLA
BSB	SZ	GM
CE	UE	GT
CLP	VEC	GV
CLZ	VER	HA
CUX	WF	HAM
DAN	WHV	HER
DEL	WL	HF
DH	WOB	HS
DUD	WST	HSK
EIN	WTL	HX
EL	WTM	JUL
EMD	<u>Nordrhein-Westfalen</u>	K
FRI	NW	KK
GAN	AH	KLE
GF	BE	KR
GO	BF	LEV
GS	BI	LH
H	BLB	LIP
HE	BM	LP
HI	BN	LUN
HK	BO	ME
HM	BOH	MG
HMU	BOR	MH
HOL	BOT	MI
LER	BUR	MK
LG	CAS	MO
MEL	COE	MON
NI	D	MS

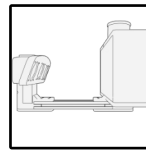
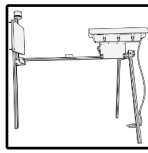

NE	KIB	BNA
OB	KL	BZ
OE	KO	C
OP	KUS	DD
PB	LD	DL
RE	LU	DW
RS	MY	DZ
SG	MYK	EB
SI	MZ	ERZ
SLE	NR	FG
SO	NW	FLO
ST	PRU	FTL
SU	PS	GC
TE	ROK	GHA
UN	RP	GR
VIE	SAB	GRH
W	SIM	GRM
WAF	SP	HC
WAN	SUW	HOT
WAR	TR	HY
WAT	WIL	KM
WES	WO	L
WIT	WW	LOB
<u>Rheinland-Pfalz</u>	ZEL	MAB
RP	<u>Saarland</u>	MEI
AW	SL	MEK
AZ	IGB	MTL
BIN	MZG	MW
BIR	NK	NOL
BIT	OTW	NY
BKS	SB	OVL
COC	SLS	OZ
DAU	VK	PIR
DIZ	WND	PL
DUW	<u>Sachsen</u>	RC
EMS	SN	RG
FT	ANA	RIE
GER	ASZ	RL
GOA	AU	SEB
GOH	BED	STL
KH	BIW	SZB

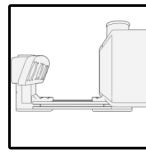
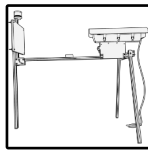

TDO	NMB	ARN
TG	OBG	ART
TO	OC	EA
V	OK	EF
WDA	QFT	EIC
WSW	QLB	EIS
WUR	RSL	G
Z	SAW	GRZ
ZI	SBK	GTH
<u>Sachsen-Anhalt</u>	SDL	HBN
ST	SFT	HIG
ASL	SGH	IK
AZE	SK	IL
BBG	SLK	J
BK	WB	KYF
BLK	WMS	LBS
BO	WR	LSZ
BRG	WSF	MGN
BTF	WZL	MHL
DE	ZE	NDH
EIL	<u>Schleswig-Holstein</u>	NH
GA	SH	PN
GHC	HEI	RU
GNT	HL	SCZ
HAL	IZ	SDH
HBS	KI	SHK
HDL	MED	SHL
HET	NF	SLF
HHM	NMS	SLN
HV	OD	SLZ
HZ	OH	SM
JE	PI	SOK
JL	PLO	SOM
KLZ	RD	SON
KOT	RZ	SRO
MD	SE	UH
MER	SL	WAK
ML	<u>Thüringen</u>	WBS
MQ	TH	WE
MSH	AP	
NEB	APD	

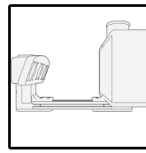
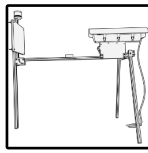

 Italy

Abruzzo

ABR
CH
PE
TE

Basilicata

BAS
PZ

Calabria

CAL
CS
KR
RC
VV

Campania

CAM
BN
CE
NA
SA

Emilia-Romagna

EMR
FE
FC
MO
PC
PR
RA
RE
RN

Friuli Venezia Giulia

FVG
PN
TS
UD

Lazio

LAZ
LT
RI

RM

VT

Liguria

LIG
IM
SP
SV

Lombardia

LOM
BS
CO
CR
LC
LO
MB
MI
MN
PV
SO
VA

Marche

MAR
AP
FM
MC
PU

Molise

MOL
IS

Piemonte

PIE
AT
BI
CN
NO
TO
VB
VC

Puglia

PUG
BR

BT

FG

LE

TA

Sardegna

SAR
CI
NU
OG
OR
OT
SS
VS

Sicilia

SIC
CL
CT
EN
ME
PA
RG
SR
TP

Toscana

TOS
FI
GR
LI
LU
MS
PI
PO
PT
SI

Trentino-Alto Adige

TAA
TN

Umbria

UMB
TR

LEPMON
Code

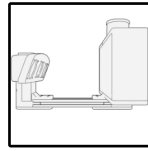
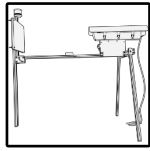

Valle d'Aosta

VDA

Veneto

VEN

PD

RO

TV

VE

VR

VI

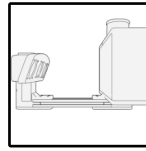
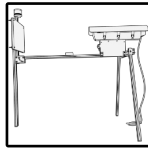

18 Promotion

With funding from the:



Federal Ministry
of Research, Technology
and Space

The project on which this report is based was funded by the German Federal Ministry of Education and Research within the Research Initiative for the Conservation of Biodiversity (FEa) under the funding code 16LW0653K. The responsibility for the content of this publication lies with the author.